



# HUMAN CARE

Your Life. Your Way.



## Convertible Chair H-250

User Manual



# Convertible Chair H-250

Part no: B1002-BL

- This operations manual provides important instructions for the safe use of Convertible Chair H-250.
- Please read this manual carefully and use the Convertible Chair only after you have developed a full understanding of its safe and correct use.
- Keep this manual where you can consult it whenever necessary.
- The information contained in this manual is subjected to change without notice.

## Content

---

<b>Assembly Process</b>	<b>3</b>
<b>Disassembly Process</b>	<b>5</b>
<b>Parts of the Chair</b>	<b>7</b>
<b>Parts of the Chair</b>	<b>8</b>
<b>Safety Notes</b>	<b>9</b>
<b>Operating the Chair</b>	<b>11</b>
<b>Maintaining the Chair</b>	<b>17</b>
<b>Troubleshooting</b>	<b>18</b>
<b>Specifications</b>	<b>18</b>
<b>Warranty</b>	<b>19</b>

# Assembly Process

## Section 1: Unpacking the Chair

- 1-1) Open box from the side labeled "Open from this End"
- 1-2) Upon opening the outer box, remove the corrugated end cap and wheel stop  
(The wheel stop is a triangle corrugated piece that keeps the chair from rolling)
- 1-3) Unlock all locking casters
- 1-4) Roll chair from side of box marked: "Open from this End"
- 1-5) Untie the string around caster at (patient) front-right side (Picture 1) (The purpose of this string is to avoid caster hitting foot frame.)
- 1-6) Save all packaging in a safe location for future use.

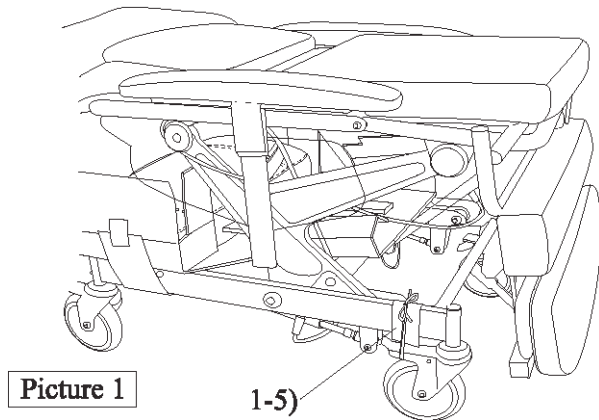

- 3-2) Remove the headrest from the corrugated box, loosen and remove headrest adjustment knob (as shown in Picture 3)  
(NOtE: Place the headrest adjustment knob somewhere safe as you will be reinstalling it shortly)

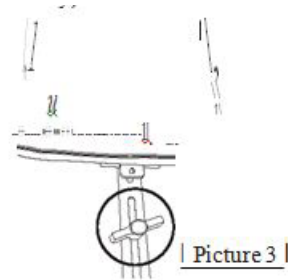

- 3-3) Insert the headrest into the backrest frame and re-attach headrest adjustment knob  
(Picture 4 through 6)

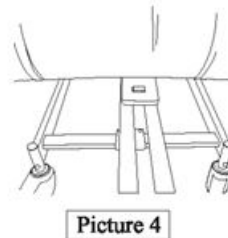

## Section 2: Assembling Legrest

- 2-1) Lift legrest with one hand, and insert the "legrest adjustment attachment" (Figure 1) to "Legrest adjustment holder" (Figure 2)

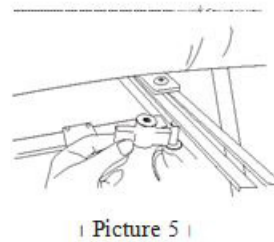
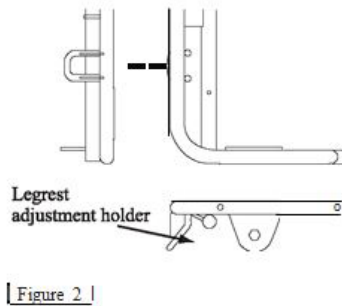
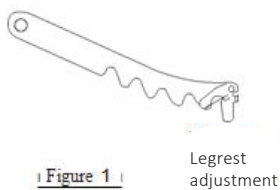

## Section 3: Assembling Headrest

- 3-1) Remove tape (as shown in Picture 2) to free the carton that includes the headrest
- 3-2) Lift (Grip) the reclining lever (wrapped with bubble wrap), so that the back rest will be lifted 30degrees (by lifting backrest by 30 degrees it is much easier to assemble the headrest)

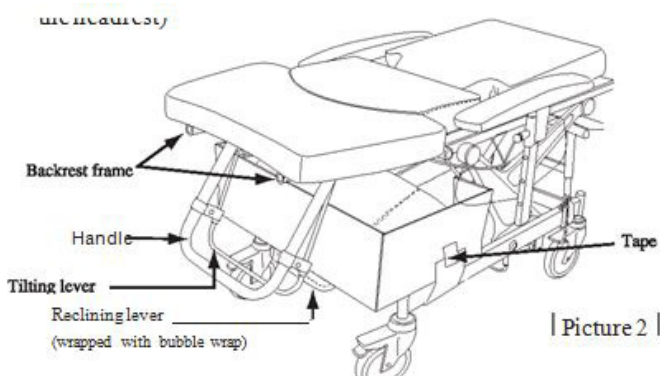

- 3-4) Attach the reclining cable to the two cable clamps that are along the chair frame as shown in pictures 8 and 9 and figure 3.  
(Insure there is no bending in the cable when attached to the clamps)

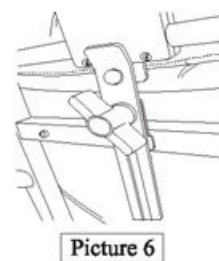

# Assembly Process

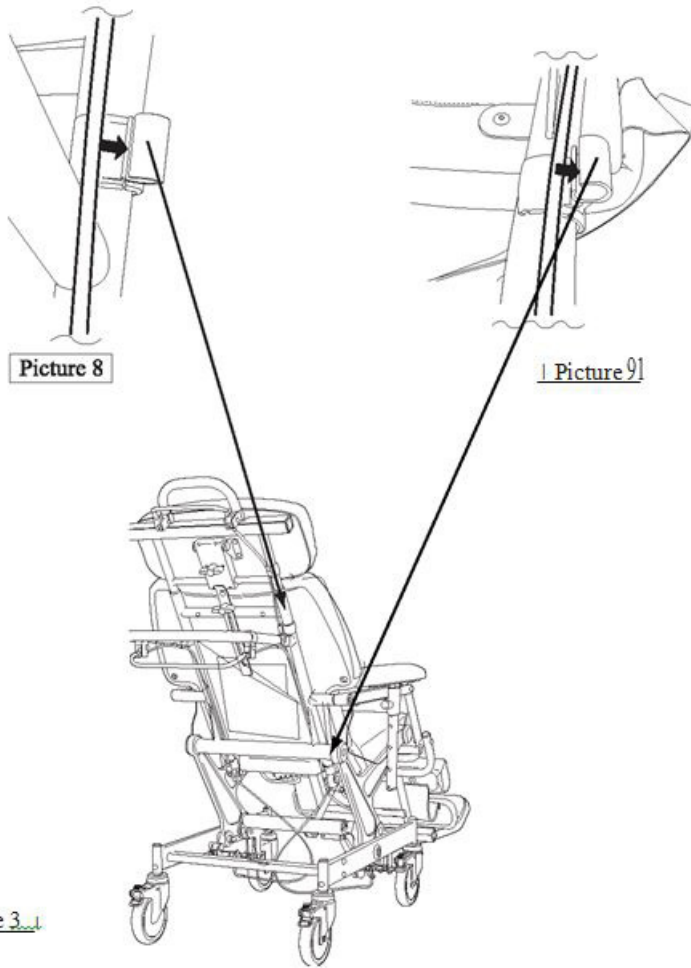

3-5) Reminder: Store the packaging box and materials in a safe place in order that they may be used in future shipments.

# Disassembly Process

## Section 1: Disassembling headrest

1-1) Detach reclining cable from the two (2) cable clamps noted in pictures 1, 2 and figure 1.

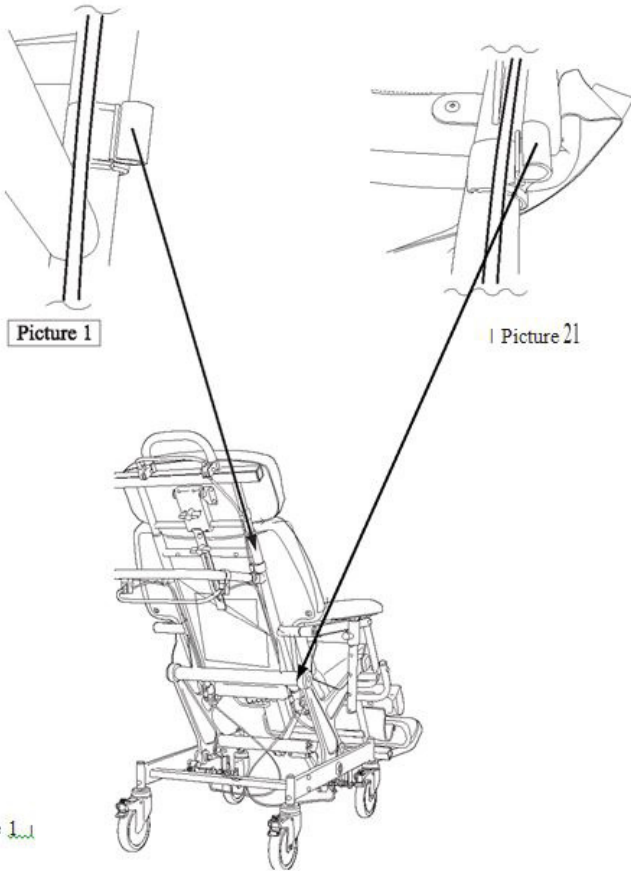
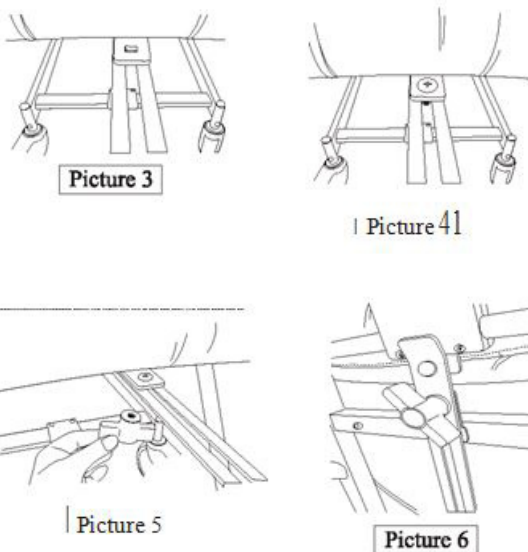
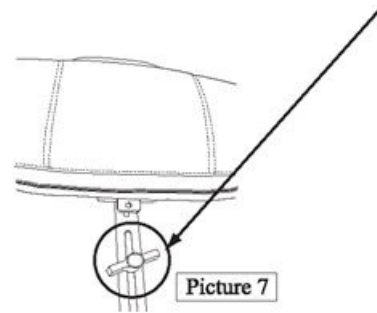

Figure 1

1-2) Loosen and remove headrest adjustment knob. Lift and remove headrest from the backrest frame. (Pictures 3, through 6)



1-3) Make sure to re-attach the headrest adjustment knob to avoid loss. (Picture 7)



1-4) Install the removed headrest assembly in the original box and place the box under the backrest as shown in picture 8.

1-5) Lift (Grip) the reclining lever J so that the back rest will be at about a 30 degree angle.

(By lifting backrest by 30 degree it will be much easier to slide the box into it's storage position).

1-6) Tape the box with the headrest assembly, in position as shown in picture 8.

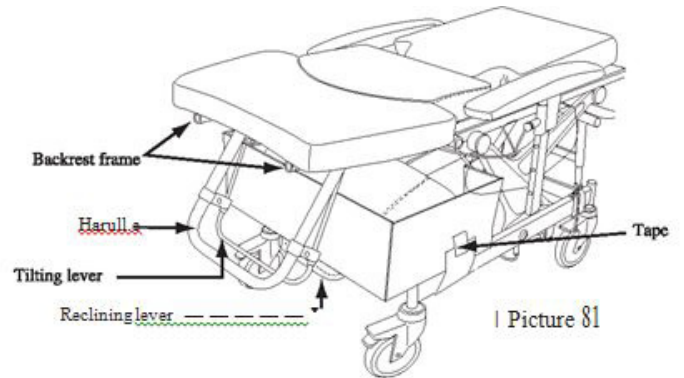

Picture 8

## Section 2: Disassembling legrest

2-1) Lift the legrest with one hand and pull out the legrest adjustment attachment from the legrest adjustment holder. (Figures 1 and 2)

\*When disassembling take out legrest adjustment attachment by swinging the pivot latch as shown Fig.3.



figure 1

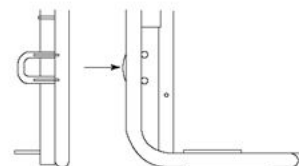

figure 2



figure 3

# Disassembly Process

## Section 3: Packaging

3-1) Position the patient front-right caster so that the locking mechanism is facing in towards the chair and set lock.

3-2) Wrap a piece of corrugated around the chair frame and tie a string at front-right side caster

(looking from the rear of the chair)

(The purpose of this string is to avoid caster hitting foot frame.)

3-3) Make sure that front-left caster is steer-locked facing front.

3-4) Check the serial number on the chair and insure the serial number labeled on the shipping box matches. If the serial numbers do not match, cross out serial number on the shipping box in all locations and write the actual chair serial number on the shipping box with a black permanent marker.

3-5) Wrap entire chair with bubble wrap material.

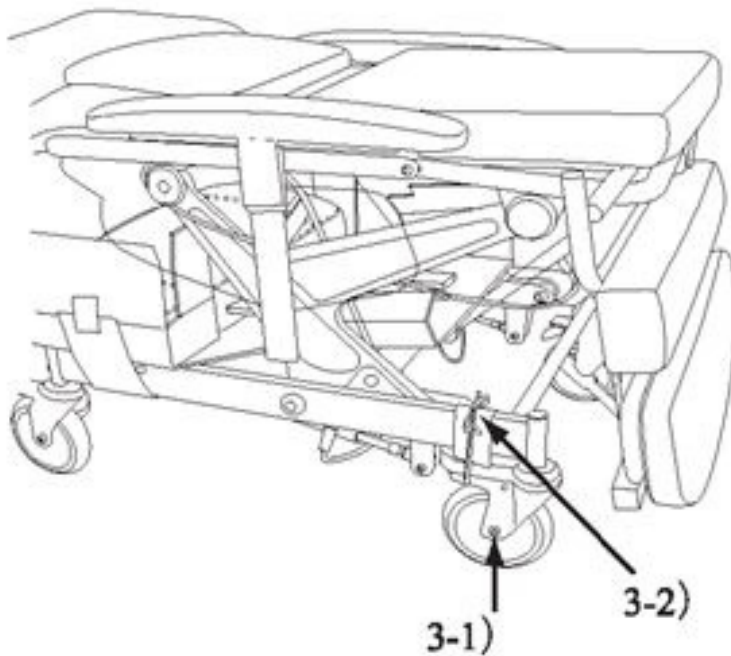

| Picture 9

3-6) Position the shipping box so that the end with "Open From this End" marking is opened.

3-7) Roll the chair into the shipping box, with head of chair first.

3-8) Once chair is rolled completely into the shipping box lock all casters.

3-9) Install the corrugated wheel stops against the casters to keep chair from rolling.

3-10) Tape wheel stops into position.

3-11) Install the corrugated end cap.

3-12) Tape the open end of the shipping box closed.

# Parts of the Chair

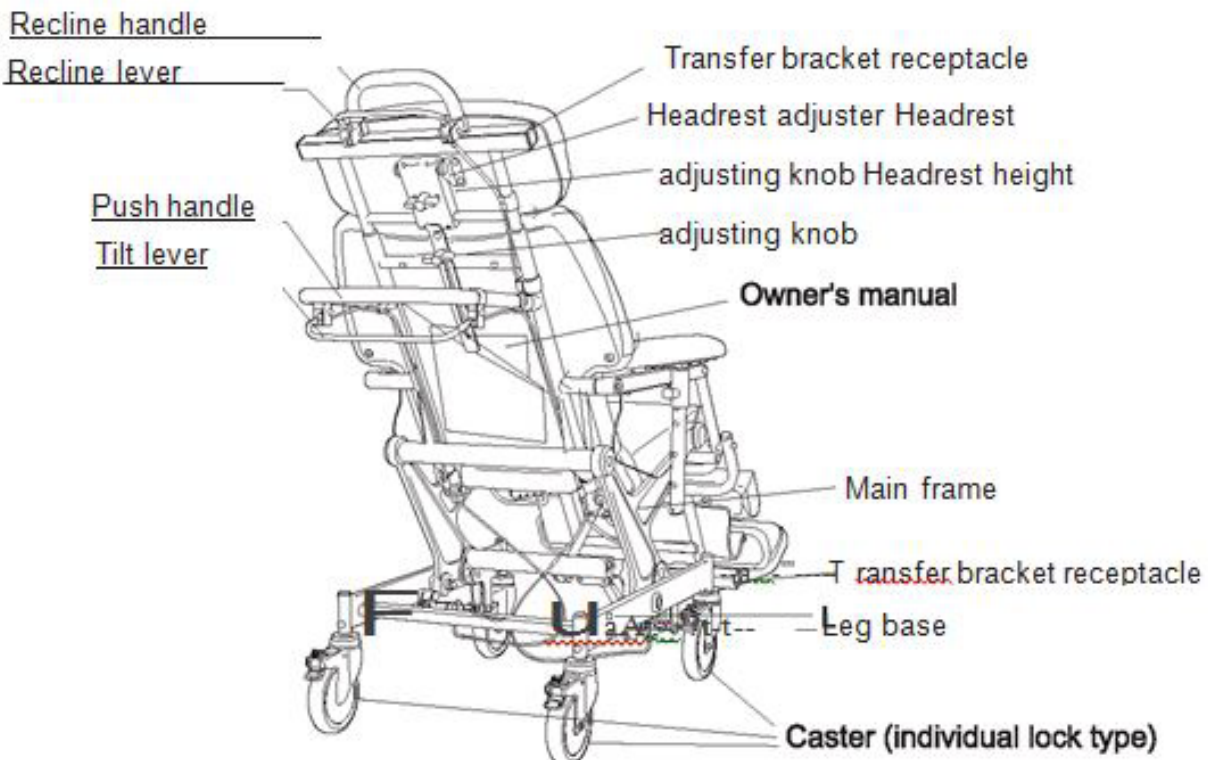
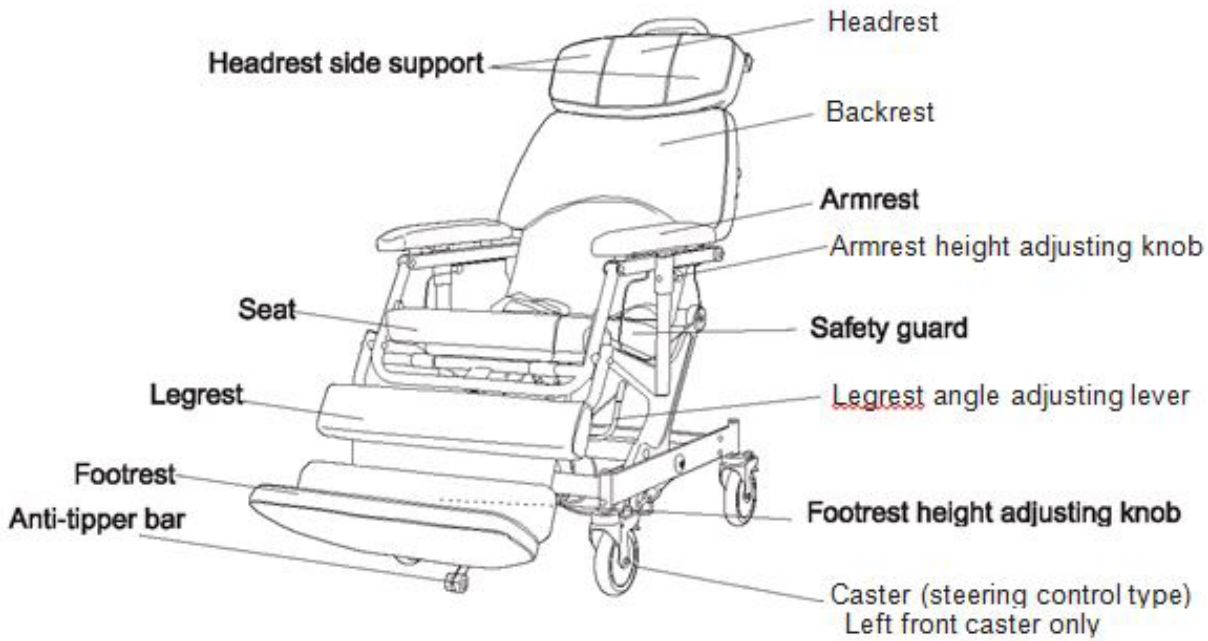

# Parts of the Chair

You must understand the warnings and cautions in this manual to use the Convertible Chair safely. Failure to observe the warnings and cautions may result in serious injury and/or mechanical failure. Please read all instructions carefully before using the chair.



**You must heed the following warnings and cautions. Failure to observe these safety precautions may result in personal injury or mechanical failure.**

- Do not use the chair near an open flame (stove, cigarette, etc.) or a high-temperature heat source.

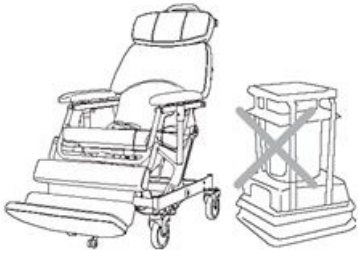

- Do not use stairs or escalators to move an occupied chair whether in the chair or the prone position.

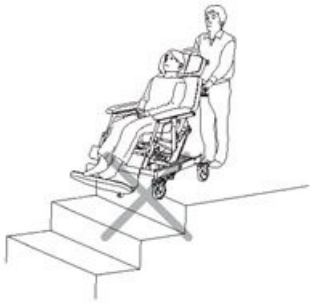

- Do not use the chair in a hyperbaric (high oxygen content/high atmospheric pressure) environment due to the possibility of static discharge.
- The maximum occupant weight for the chair is 250 lbs. People who weigh more cannot use the Convertible Chair H-250.
- Do not use the footrest as a step when getting into or out of the chair. The footrest should be in its folded position to avoid tripping the patient or tipping the chair.

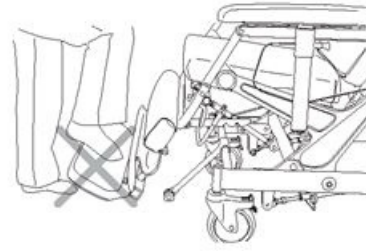

- Take special care when going up or down a ramp or slope. Be sure to lock the steering caster when traversing an incline or decline. Never park the chair on a ramp or slope.

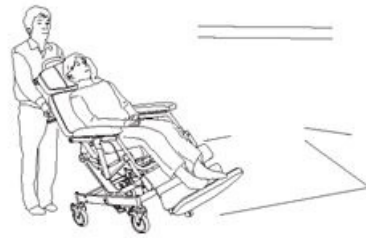

- Remove the seatbelt from around the patient when changing from the prone to the chair position. Otherwise the seatbelt will tighten, which may result in serious injury to the patient.



# Safety Notes



**You must heed the following warnings and cautions. Failure to observe these safety precautions may result in personal injury or mechanical failure.**

- Do not use the chair on gravel, wet, or frozen roads, or on any surface that is extremely slick or wet.

- Caster locks are not designed to stop the chair. Do not use the caster control pedals to stop the chair in motion.



- Take special care to lock the casters securely when reclining or inclining the chair or when transferring the patient to or from the chair.

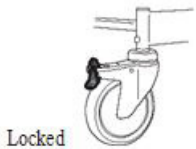

- Do not confuse the headrest and footrest when placing the patient in the prone position.



- Always raise the armrests whenever the patient is lying on the chair in the prone position.



- Make sure all persons and objects are clear of the chair when reclining or inclining the chair.



- Do not allow the patient to sit on the chair when it is in the prone position. Never sit or lean on the headrest or the legrest when the chair is in the prone position.



**You must heed the following warnings and cautions. Failure to observe these safety precautions may result in personal injury or mechanical failure.**

- Do not move the chair using the armrest.

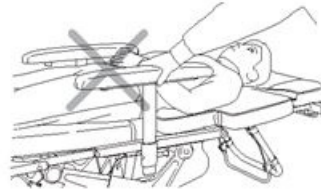

- The chair is designed for a single occupant. Never allow two or more people to sit or lie on the chair. Do not place any other heavy object on it.



- The Convertible Chair is not designed as a weight training or rehabilitation apparatus. Never use it for such purposes.

- Do not jump up and down on the back cushion or seat cushion.



- Do not use a chair with any missing or damaged parts.

- Never disassemble or remodel the Convertible Chair. If problems arise, contact Human Care or your authorized dealership.

# Safety Notes

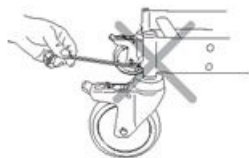

## **Perform the following checks before using the chair:**

1. Casters can be locked (individual lock type and steering control type).
2. Reclining mechanism works smoothly and stops in any desired position.
3. Height and angle of the footrest and the height, angle and depth of the headrest can be adjusted properly.
4. Height adjustment of the armrests can be made properly.
5. Tilting mechanism can be operated smoothly and can be stopped in any desired position.

***If problems are found, contact Human Care at 1-877-822-7866 or your authorized Medical dealership.***

## **Adjusting the Footrest**

The Convertible Chair is packaged with the footrest folded up.

# Operating the Chair

## Raising and lowering the footrest

Adjust the height of the footrest to comfortably accommodate the patient.



**Always use both hands when raising or lowering the footrest. Otherwise an injury or accident may occur.**

1. Support the footrest from underneath with one hand and loosen the footrest height adjusting knob with the other.
2. Slowly push the footrest up or down.
3. When the footrest reaches the desired height, tighten the knob fully.



## Positioning the footrest for use



**Never use the footrest at any angle between 0 degrees and 90 degrees. Otherwise the footrest may suddenly fold or unfold and cause an injury or accident.**

1. Rotate the footrest to the 90-degree position for a patient in the seated position.
2. Fold the footrest up completely for a patient in the prone position.

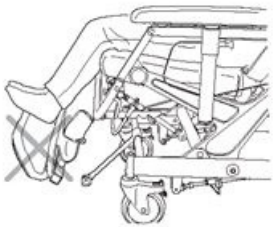

## Lowering the footrest for a taU patient

The footrest can be lowered further if necessary to accommodate a tall patient. A 5-mm Allen wrench and a 13-mm or adjustable wrench are needed to perform this adjustment.



**Always use both hands when raising or lowering the footrest. Otherwise an injury or accident may occur.**



**Be sure to tilt the legrest or the chair to avoid damaging the underside of the footrest.**

1. While using the Allen wrench to keep the stop bolt from turning, use the adjustable wrench to remove the stop nut (shown in the illustration).
2. Support the footrest from underneath with one hand and loosen the footrest height adjusting grip with the other.
3. Slowly push the footrest down.
4. When the footrest reaches the desired height, tighten the grip fully.
5. Tilt the legrest up or the chair backwards slightly so the footrest does not drag on the ground when moving the chair.

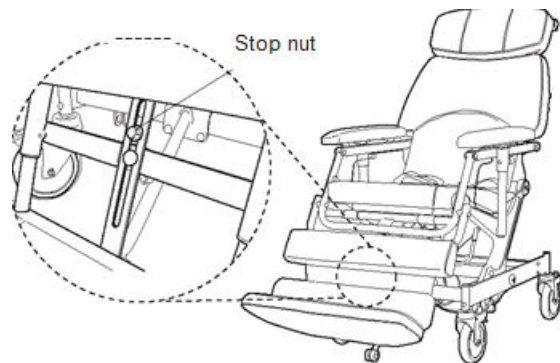

## Adjusting the Legrest

The angle of the legrest can be adjusted to four levels.



**Be sure to hold the footrest with one hand when performing the angle adjustment. Moving the lever only may cause an abrupt angle change, which may cause stress to the patient or cause an accident or mechanical trouble.**

# Operating the Chair

## Raising the legrest

1. Support the end of the footrest from underneath with both hands.
2. Slowly raise the legrest until you hear a click.
3. If you continue to raise the legrest, you will hear additional clicks. Stop at the desired angle.

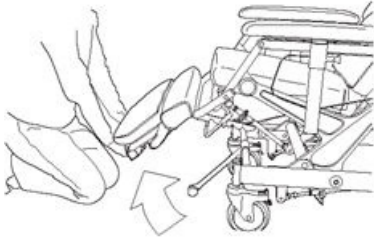

## Lowering the legrest

1. Raise the footrest a little with one hand.
2. Grip the legrest angle adjusting lever with the other hand and slowly lower the legrest.

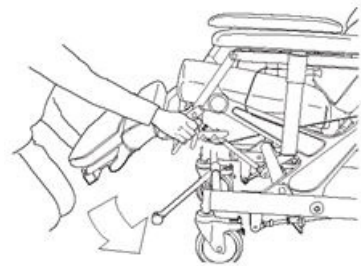

## Tilting the legrest for a tall patient



**Be sure to tilt the legrest or the chair to avoid damaging the underside of the footrest.**

Raise the legrest to position two (next to lowest), three, or four (highest) for a tall patient, as described above.

## Adjusting the Headrest

The headrest allows the patient's head to be held comfortably and securely while they are in the chair. Make the depth and angle adjustment together with the height adjustment to suit the figure of the patient.



**Always use both hands when raising or lowering the headrest. Never let go of the reclining handle until the knob is tightened.**

1. Hold the recline handle with one hand, and loosen the headrest height adjusting knob with the other. Then slowly raise or lower the headrest.
2. When the headrest reaches the desired height, tighten the knob fully.

## Adjusting the depth and angle

The headrest aduster changes the depth and angle of the headrest at the same time.

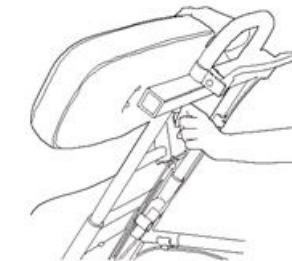

**Never let go of the headrest until the headrest adjusting knob is tightened.**

1. Hold the headrest with one hand and loosen the headrest adjusting knob with the other hand. Then adjust the headrest position by pushing the headrest forward.
2. When the headrest position is determined, tighten the headrest adjusting knob fully.
3. Straighten the headrest support to its original position by restoring the depth/angle of headrest to home position.
4. Hold the headrest with one hand and loosen the headrest adjusting knob with the other hand. Then pull the headrest backward and up to restore it to the home position (flat to the back of the chair frame).
5. When the headrest is back in home position, tighten the headrest adjusting knob.

# Operating the Chair

## Adjusting the Headrest Side Supports

The headrest side supports help keep the patient's head from turning or drooping and help keep the neck straight.



**Before the chair is transformed to the prone position, lower the headrest so it is flush with the back cushion. Failure to do so could cause the patient's head to drop between backrest and headrest, and an injury or accident may occur.**

1. Hold the middle part of the headrest with one hand and slowly move one side at a time forward with the other hand.

2. To return the headrest support to its original position, hold the middle part with one hand and slowly pull one side at a time backward with the other hand.



## Adjusting the Armrests

The armrests function as guardrails to prevent the patient from falling when the chair is in the prone position. They also function as the supports for the patient's upper body when in a sitting position.

The height of the armrests can be adjusted to five levels.

The height is set with the tip of the armrest height adjusting knob inserted into one of the holes in the rear of the pipe. Pull the knob out and raise

the armrest slowly until you hear a click, which indicates engagement.

### Raising the armrest



**After adjusting the armrest make sure the armrest height adjusting knob is locked in place, or injury may occur.**

1. While holding the armrest with one hand, pull out the armrest height adjusting knob with the other hand. Gently pull on the armrest to raise it.

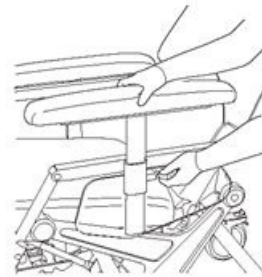

When the armrest has reached the desired height, release the armrest height adjusting knob. This locks the armrest into position.

### Lowering the armrest



**After adjusting the armrest make sure the armrest height adjusting knob is locked in place, or injury may occur.**

1. While holding the armrest with one hand, pull out the armrest height adjusting knob with the other hand. Gently push on the armrest to lower it.

2. Once the armrest has reached the desired height, release the armrest height adjusting knob. This locks the armrest into position.

# Operating the Chair

## Steering the Chair

The Convertible Chair H-250 can be steered in two modes: with the steering locked or with all four casters able to move independently. The left front caster is the motion control type. This caster has a control pedal labeled "Steering" and is used primarily for steering.

### Using the steering lock function

The steering lock function allows you to easily steer the chair in a straight line. Only the left front caster has this function.

1. Step down on the back of the steering caster control pedal until it clicks. Then move the chair in a straight line about 3 feet backward or forward to set the lock. This action will keep the caster from swiveling and allow better forward and backward movement of the chair. The chair can now be moved with greater stability.

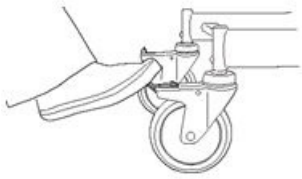

### Using the 4-caster free function

In the 4-caster free mode, all four casters move independently, allowing the chair to be easily brought alongside a bed. In this mode all four casters are unlocked.



**When setting the casters free by the caster control pedal, do not put your finger in the square opening in the control pedal.**

**Do not use the 4-caster free function when moving a patient across an incline. The chair may roll down the incline and an injury may occur.**

1. To ensure the casters are unlocked, step down on the front of the control pedal of each caster.

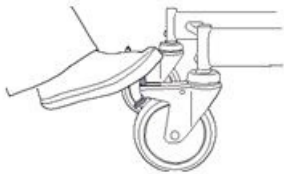

## Locking the Casters

The locking function holds the chair motionless when parking the chair, when transforming it from the chair to the prone position or from the prone to the chair position, and when transferring the patient to and from a bed. Three casters (both rear and the right front) are the individual lock type casters. These casters have control pedals labeled "Brake."



**The caster lock is not designed to stop the chair in motion. Do not operate the caster control pedal while moving the chair.**

1. To lock the casters, step down on the back of the control pedal on each individual lock type caster until it clicks into place, ensuring each one is fully down. This locks both the caster swivel and wheel rotation.
2. To unlock the casters, step down on the front of the control pedal on each individual lock type caster until the lock releases.

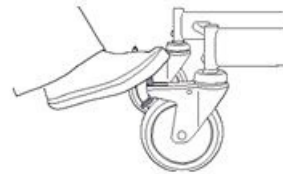

# Operating the Chair

## Using the Tilt-n-Space Feature

The Tilt-n-Space feature is designed to tilt the chair within the frame to ensure the patient's comfort and safety while seated in the chair by relieving pressure.



**Never recline the patient to the prone (horizontal) position before attempting to use the Tilt-n-Space feature. The chair may recline abruptly and an injury or accident may occur.**

### Tilting the chair



**Make sure that the casters are locked. Otherwise the force applied may not allow the tilt mechanism to function properly.**

1. Hold the push handle and the tilt lever at the same time and squeeze them together with both hands as illustrated. Slowly push down.

2. When the back reaches the desired angle, release the tilt lever. The tilt is adjustable to any angle up to 17 degrees from upright.

### Returning the chair to its original position



**Restore the tilt mechanism to the upright position before reclining the chair to the prone position. Failure to do so may cause the patient to slip head first from the chair and an injury or accident may occur.**

1. Hold the push handle and the tilt lever at the same time and squeeze them together with both hands as illustrated. Slowly pull up.

2. When the desired angle is reached, release the tilt lever.

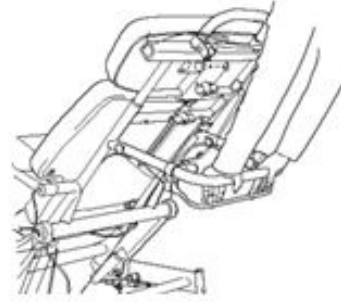
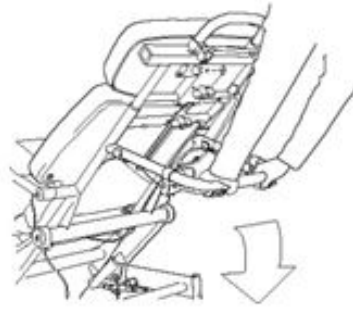

# Operating the Chair

## Changing Between Chair and Prone Positions

The chair back stops at any angle between the prone (horizontal) position and an upright angle of about 70 degrees.

The Convertable Chair is not designed to be used as a stretcher to move patients and it is not recommended for such use.



**Before reclining or inclining the chair, always ensure that the casters are locked. Otherwise the chair may begin moving during the reclining operation, and an injury or accident may occur.**



**Always recline and incline the chair slowly.**

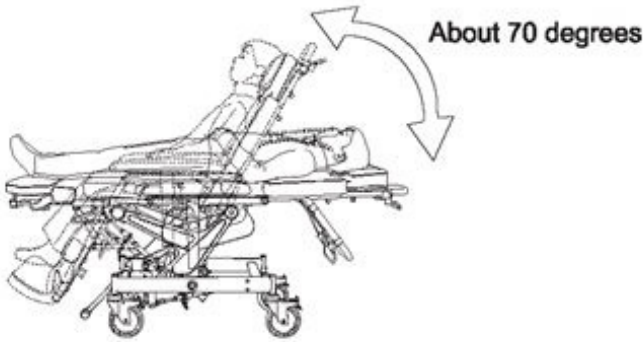

### Changing from the chair to the prone position

Putting the chair in the prone position allows easy transfer of the patient from the chair to the bed and vice versa.



**Restore the tilting mechanism to the upright position before reclining the chair to the prone position. Failure to do so may cause the patient to slip head first from the chair and an injury or accident may occur.**

You must restore the Tilt-n-Space mechanism to the upright position before reclining the chair to the prone position. If you realize during the reclining operation that the tilting mechanism is not in the upright position, stop the operation immediately, return to the chair position, and move the Tilt-n-Space mechanism to the upright position. Then change the chair to the prone position.



**Do not allow the patient's hands to slip between the safety guard and the frame, or injury may occur.**



**Always use both hands when raising or lowering the seat back.**

1. While holding the recline handle, squeeze the recline lever and recline handle together as illustrated. Slowly lower the recline handle.



Do not snap the recline lever. Allowing the recline lever to snap back into position may lead to mechanical problems.

2. Release the recline lever when the back reaches the desired angle.

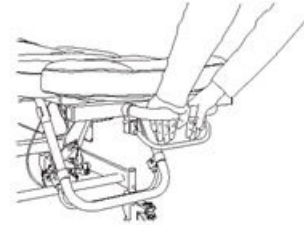
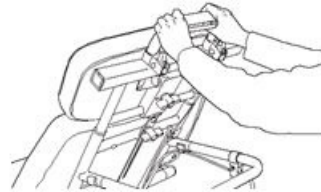

**Remove the seatbelt from around the patient when changing from the prone to the chair position. Otherwise the seatbelt will tighten, which may result in serious injury to the patient.**



**Always use both hands when raising or lowering the seat back.**

1. While holding the recline handle, squeeze the recline lever and recline handle together as illustrated. Slowly raise the recline handle.



**Do not snap the recline lever. Allowing the recline lever to snap back into position may lead to mechanical problems.**

2. Release the recline lever when the back reaches the desired angle.

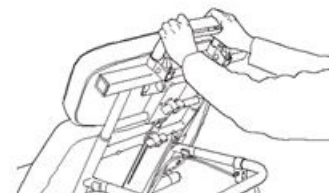
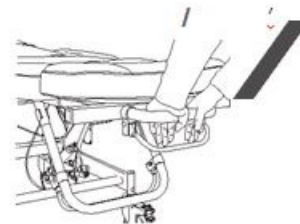



# Operating the Chair

## Changing to the Trendelenburg Position



The Trendelenburg position should only be attempted when the patient has been secured in the chair with a Medical-approved harness-type restraint device. Failure to do so may cause the patient to slip head first from the chair and an injury or accident may occur.



Never recline the patient to the prone position and then attempt to use the Tilt-n-Space feature.

The chair may recline abruptly and an injury or accident may occur.



Do not allow the patient's hands to slip between the safety guard and the frame, or injury may occur.



Always use both hands when raising or lowering the seat back.

1. Tilt the chair back using the Tilt-n-Space mechanism (as described on page 13).

2. While holding the recline handle, squeeze the recline lever and recline handle (as described on page 15). Slowly lower the recline handle.



Do not snap the recline lever. Allowing the recline lever to snap back into position may lead to mechanical problems.

2. Release the recline lever when the back reaches the desired angle.

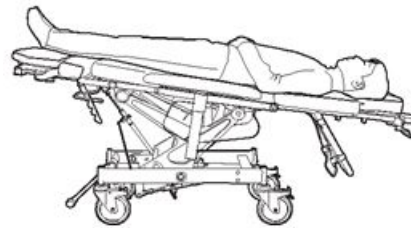

# Maintaining the Chair

## Checks

The Convertible Chair H-250 is designed for enhanced safety and durability. It is subject to wear and tear resulting from the place, length, and other conditions of use. For longer use, periodically inspect all parts and have them replaced as needed.

- Check the cushions for rips or tears.
- Check the tilt and recline levers to make sure they move freely.
- Check the cables to make sure they are securely attached to the locking cylinders.
- Check the anti-tipper bar and frame attachment member to make sure they are not bent.
- Check the chair recline and Tilt-n-Space features to make sure they are working properly.

## Maintenance

Moisture can cause rusting and noisy operation. Take care to wipe off any moisture present on the Convertible Chair.

## Cleaning



**Before using any cleaning product, test it on the underside of the chair seat. Never use any volatile fluid (thinner, gasoline, etc.) that could cause discoloration or deterioration.**

Use mild soap and water or a nonabrasive hospital-grade detergent disinfectant to clean the chair. First, wet a cloth with the cleaning product and wring it dry. Then gently wipe off the chair.

# Troubleshooting

Before contacting Human Care or your authorized dealer for repair, please make the following checks.

Trouble	Check	Correction
Does not move	Caster lock	Release the caster lock.
Does not go straight	Position of caster control pedal	Use the steering lock function of casters
Will not recline	Wire cable	Make sure the cable is attached to the handle properly and the cable is securely attached to the locking cylinder.
Tilt-n-Space mechanism not working properly	Wire cable	Make sure the cable is attached to the handle properly and the cable is securely attached to the locking cylinder.
Headrest/footrest not locked	Tightness of the adjusting knob	Tighten the adjusting knob.

# Specifications

Product name	H-250 convertible chair
Model	H-250
Maximum occupant weight	250 lbs
Overall height	Prone: 26 inches, Wheelchair: 53 to 60 inches
Overall length	Prone: 71 to 84 inches, Wheelchair: 49 to 51.5 inches
Overall width	24.5 inches
Weight	123 lbs
Seat width	17 inches
Seat depth	18.5 inches
Back angle	0 to 70 degrees
Tilt-n-Space angle	0 to 17 degrees
Headrest adjustable height	7 inches
Footrest adjustable height	6 inches
Casters	Three individual lock type, one steering control type
Frame	Steel pipe frame, aluminum
Cushion	Nylon top coating, vinyl chloride coating

# Warranty

## Convertible Chair H-250

PLEASE NOTE: The warranty below has been drafted to comply with Federal Law applicable to products manufactured after July 4, 1975.

This warranty is extended only to the original purchaser/user of our products.

This warranty gives you specific legal rights and you may also have other legal rights, which vary from state to state.

Human Care warrants the chair frame to be free from defects in materials and workmanship for a period of three (3) years from date of purchase. Wear items including, but not limited to: upholstery, casters, locking cylinder, release cable, recline release handle, guide rod wear strips, and seat frame wear collars are warranted to be free of defects in material and workmanship for a period of one (1) year. If within such warranty period any such products shall be proven to be defective, such product shall be repaired or replaced, at Human Care's option.

This warranty does not include any labor or shipping charges incurred in replacement part installation or repair of any such product. Medical's sole obligation and your exclusive remedy under this warranty shall be limited to such repair and/or replacement.

For warranty service, please contact Human Care. Do not return products without our prior consent.

LIMITATIONS AND EXCLUSIONS The foregoing warranty shall not apply to:

- Serial numbered products if the serial number has been removed or defaced;
- Products subjected to negligence, accident, or improper operation, maintenance, or storage;
- Products modified without Human Care's express written consent including, but not limited to, modification through the use of unauthorized parts or attachments;
- Products damaged by reason of repairs made to any component without the specific consent of Human Care; or to
- Products damaged by circumstances beyond Human Care's control.

Such evaluation will be solely determined by Human Care. The warranty shall not apply to problems arising from normal wear or failure to adhere to these instructions.

The foregoing warranty is exclusive and in lieu of all other express warranties. Implied warranties, if any, including the implied warranties of merchantability and fitness for a particular purpose, shall not extend beyond the duration of the expressed warranty provided herein and the remedy for violations of any implied warranty shall be limited to repair or replacement of the defective product pursuant to the terms contained herein. Human Care shall not be liable for any consequential or incidental damages whatsoever.

This warranty shall be extended to comply with state/provincial laws and requirements.

**HUMAN CARE SWEDEN (HQ)**

Årstaängsvägen 21C  
117 43 Stockholm  
Phone:- +46 8 665 35 00  
Fax:- +46 8 665 35 10  
E-post: info.se@humancaregroup.com  
www.humancare.se

**HUMAN CARE CANADA**

10-155 Colonnade Road  
Ottawa, ON K2E 7K1  
Phone:- 613.723.6734  
Fax:- 613.723.1058  
Email: info.ca@humancaregroup.com  
www.humancaregroup.com

**HUMAN CARE UNITED STATES**

4210 S. Industrial Drive, Suite 160  
Austin, TX 78744  
Phone: 512.476.7199  
Fax: 512.476.7190  
Email: info.us@humancaregroup.com  
www.humancaregroup.com

**HUMAN CARE AUSTRALIA**

Unit 9, 271 Wells Road  
Chelsea Heights, Victoria 3196  
Phone:- +61 3 8773 1111  
Fax:- +61 3 9773 4008  
Email: info.au@humancaregroup.com  
www.humancaregroup.com

CE



**HUMAN CARE**  
Your Life. Your Way.