

Titan Series Commercial Ramp System

Installation Manual

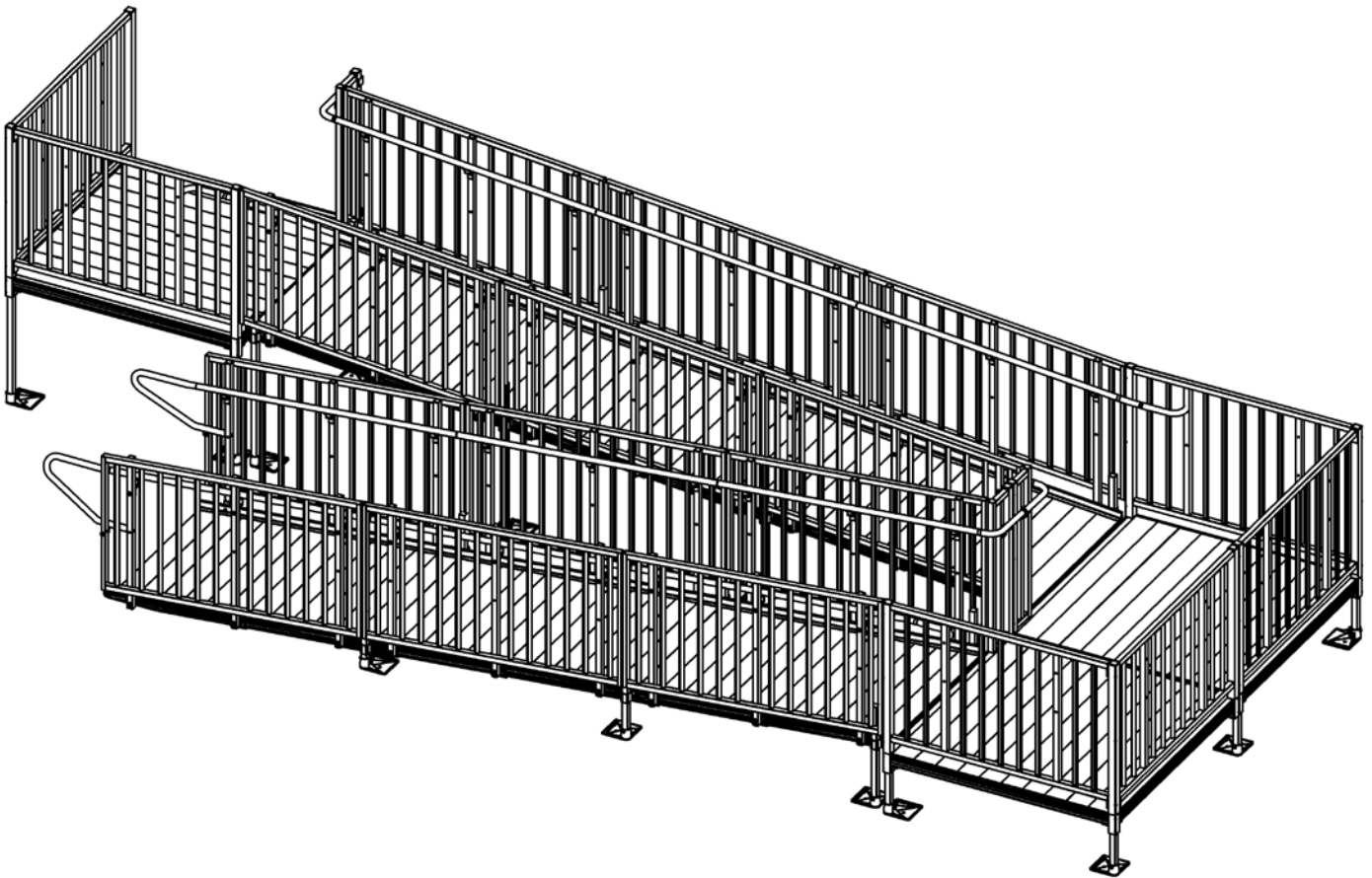

Manufactured in the USA

BEFORE YOU BEGIN

SYMBOL AND SYMBOL MEANINGS

WARNING SYMBOL

FIG. A FIG. A depicts the **WARNING** symbol. Black and White, as shown at right, is the preferred **WARNING** symbol color. This symbol may appear in various colors and in conjunction with other symbols.

When the word **WARNING** is written, it will be in all caps and bold font.

The **WARNING** symbol indicates a failure to obey the safety warning could result in property damage, damage to equipment, serious personal injury or death as well as the serious personal injury or death of others.

NOTE SYMBOL

FIG. B FIG. B depicts the **NOTE** symbol. This symbol may appear in various colors and in conjunction with other symbols. The symbol indicates a failure to obey the note could result in improper operation, less than optimal performance, the creation of a potentially dangerous situation, and, at the sole discretion of the manufacturer, may void your warranty.

NOTE AND WARNING SYMBOL USED TOGETHER

FIG. C When the **NOTE** and **WARNING** symbols appear in conjunction with one another, the **NOTE** symbol precedes the **WARNING** symbol as seen in FIG. C.

 **WARNING** Read and follow all labels and assembly instructions, including warnings and cautions, prior to assembly and use!

 **WARNING** Load Rating: 100 lbs. psf live load, 300 lbs. concentrated load. Never exceed Load Rating

INSPECTION AND PROPER SET UP (BEFORE USE):

 Inspect for damaged or missing parts before use. If damaged or missing parts are noted, **DO NOT USE!**

 If any part of the system is loose, **DO NOT USE** until repairs can be made by a certified installer or other qualified person.

SYSTEM USE:

 **WARNING** Metal conducts electricity. Do not use near exposed wiring or hang lights from system.

 Ensure all fasteners and locking mechanisms are in place and tightened. Regularly check and tighten as needed.

 Consult your local building codes concerning securing system for wind, seismic, and other applicable loads.

 Use ramp only with a qualified helper.

 Always follow your mobile equipment manufacturer's instructions while operating such equipment on this system,

 Refer to your product Owner's Manual for the proper degree of incline/decline and chair direction of your mobile device. Never exceed equipment manufacturer's recommendations.

 Do not use if walking surface is unsafe.

 Ramp may be slippery when wet or icy.

 Proper maintenance and upkeep to the system is vital. **DO NOT USE** if ramp guards, handrails, or supports are damaged or unstable.

 Confirm that the system is correctly leveled and positioned securely. Periodically check for ground shifts.

 If any part of the system is damaged or loose, **DO NOT USE** until repairs can be made by a certified installer or other qualified person.

 Never place anything under or attach anything to system to gain height or to adjust for uneven surfaces.

 Do not use any component not supplied or approved by manufacturer with system.







 Do not sit, stand, or climb on guards or handrails.

 Do not play on or around system, including, but not limited to, running, jumping, bicycles, scooters, skateboards, etc.

 Do not use handrails or ramp to support planters, decorations, etc.

 Properly support and restrain system in transit and storage.

MAINTENANCE:

-  Proper maintenance and upkeep to the system is vital. DO NOT USE if ramp guards, handrails, or supports are damaged or unstable.
-  Do not use if surface is covered with ice and/or snow. Accumulation must be shoveled and the tread surface swept clean before use.
-  At all times, keep system clear of dirt, leaves, and other debris that may accumulate on the surface.
-  Confirm that the system is correctly leveled and positioned securely. Periodically check for ground shifts.
-  Ensure all fasteners and locking mechanisms are in place and tightened. Regularly check and tighten as needed.
-  Ramp may be cleaned with mild detergent and warm water (consult manufacturer before using abrasives or chemical cleaners). Rinse well and use extra caution when ramp surface is wet.

TOOLS NEEDED:

- ✓ Tape measure
- ✓ Level
- ✓ 9/16" socket or wrench
- ✓ 1/2" socket or wrench
- ✓ 3/16" hex key wrench
- ✓ 5/32" hex key wrench
- ✓ 5/16" masonry drill bit (if installing ramp to concrete porch, steps, etc.)
- ✓ Hammer
- ✓ #3 square drive bit
- ✓ File
- ✓ Power drill
- ✓ Metal cutting chop saw or reciprocating saw
- ✓ Digging tools (if an obstacle needs to be removed)
- ✓ Two able-bodied persons needed for installation
- ✓ Pop rivet gun (needed for child rail and corner cover plate installation only)

TABLE OF CONTENTS

Before You Begin, Symbol and Symbol Meanings, System Use	2
Tools Needed	2
Maintenance	3
Assemble/Set Platforms	3
Assemble/Set Ramps	9
Installing Transition Plate(S)	10
Installing Support Tubes (Legs) To Ramp Section(S)	11
Installing Platform Guards	14
Installing Ramp Guards	19
Installing Handrails	20
Installing Handrail Attachments	20
Final Steps	25
Notes	26

COMMON RAMP CONFIGURATIONS

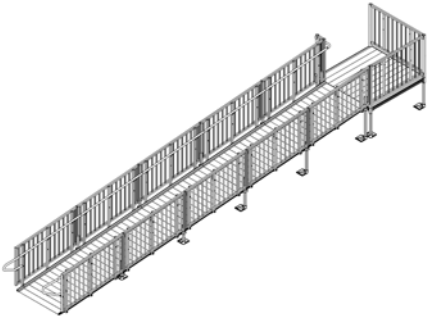

Straight System
(Over 30' Long Requires Resting Platform)

FIG. 1

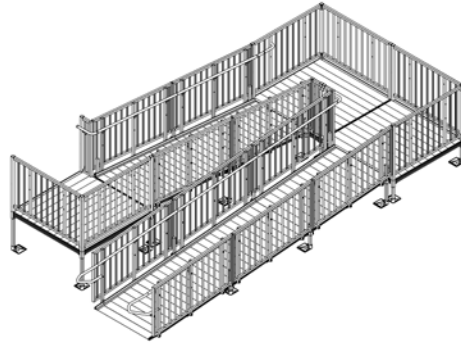

Turn Back (or Switchback) System

FIG. 2

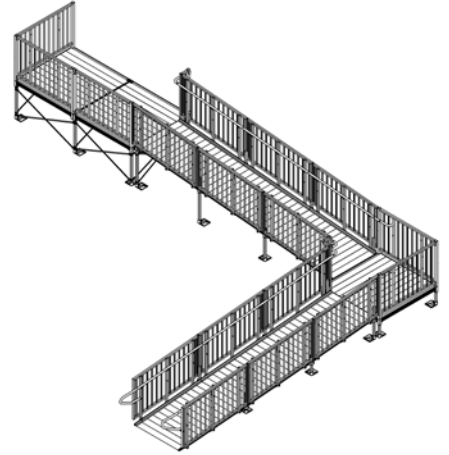

Corner Turn System

FIG. 3

1. ASSEMBLE/SET PLATFORMS:

Our standard platform sizes are available in; 5' x 5', 6' x 6', 5' x 6' and 5' x 7'. Consult manufacturer for custom sizes.

- 1.1 Determine the platform height required for the location.
- 1.2 Insert a support tube (leg) through a corner pocket at corner of the platform and into the foot (FIG. 4). Orient all feet so they do not protrude past the perimeter of the platform.
- 1.3 Use hole in the foot as a template to drill 11/32" or 3/8" hole through the support tube.
- 1.4 Install a 5/16"-18 x 3" long hex bolt through the support tube and foot then secure with the 5/16"-18 nylon insert locknut and tighten the thumb screw securely.
- 1.5 Ensure that the correct length support tubes are used.
 - ⚠ The support tubes are also used to support the guardrails. When installed, the support tubes must extend at least 24" above the platform walking surface (FIG. 5).
- 1.6 Adjust platform to approximate height required then secure the support tube by tightening setscrews in the corner pocket with 3/16" hex key wrench.
- 1.7 Repeat at all four corners of the platform unless using a platform connector (refer to 1.12)
- 1.8 Position platform in final location then make height and level adjustments as needed.
- 1.9 Check to confirm all setscrews securing the support tubes are fully tightened and the support tubes cannot move with respect to the platform (a total of eight, two in each corner).
- 1.10 Assemble all platforms, support tubes and feet required in this fashion. Guardrails and handrails will be installed after platforms and ramps are assembled and set.

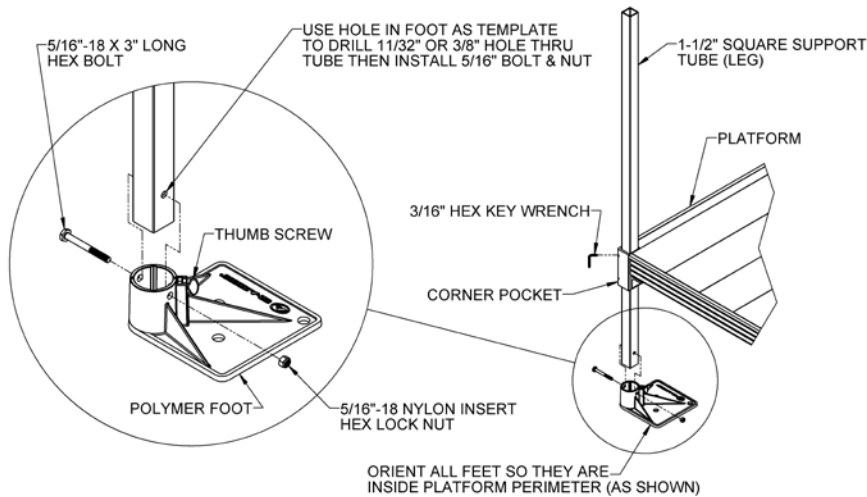

FIG. 4

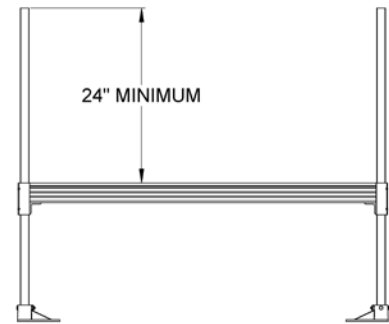

FIG. 5

- 1.11 Platforms over 3 feet high from the ground require cross bracing.
 - 1.11.1 Insert support tubes into platform, assemble the feet and set platform at required height as described in previous steps.
 - 1.11.2 Separate ends of brace bands until they go around the 1-1/2" square support tube and install four bands on each leg with the part containing bolt holes at 90 degrees from each other and in line with the outer edge of the foot (FIG. 6).
 - 1.11.3 The cross brace will come assembled with one bolt in the center. The brace assembly should be placed approximately in the middle of the platform legs on all four sides with the top brace bands a minimum of 2 feet from the bottom brace bands.
 - 1.11.4 If needed for the location, trim the ends of the cross brace assembly to fit.
 - 1.11.5 Drill one 11/32" dia. hole on center approximately 1/2" from both ends of each brace.
 - 1.11.6 Install cross brace assembly using four 5/16"-18 x 1-1/2" long square neck carriage bolts, nuts and washers in the desired location (FIG. 7).
 - 1.11.7 Tighten all fasteners securely.

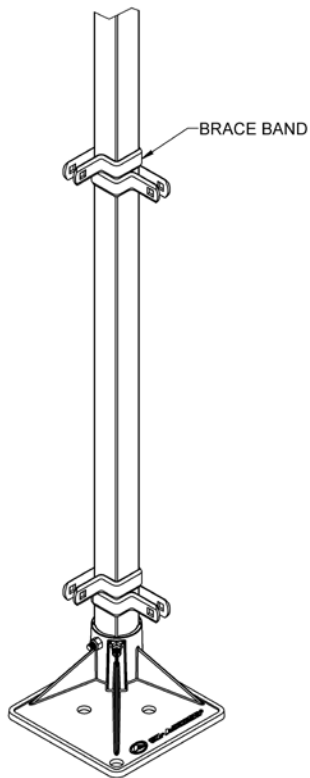

FIG. 6

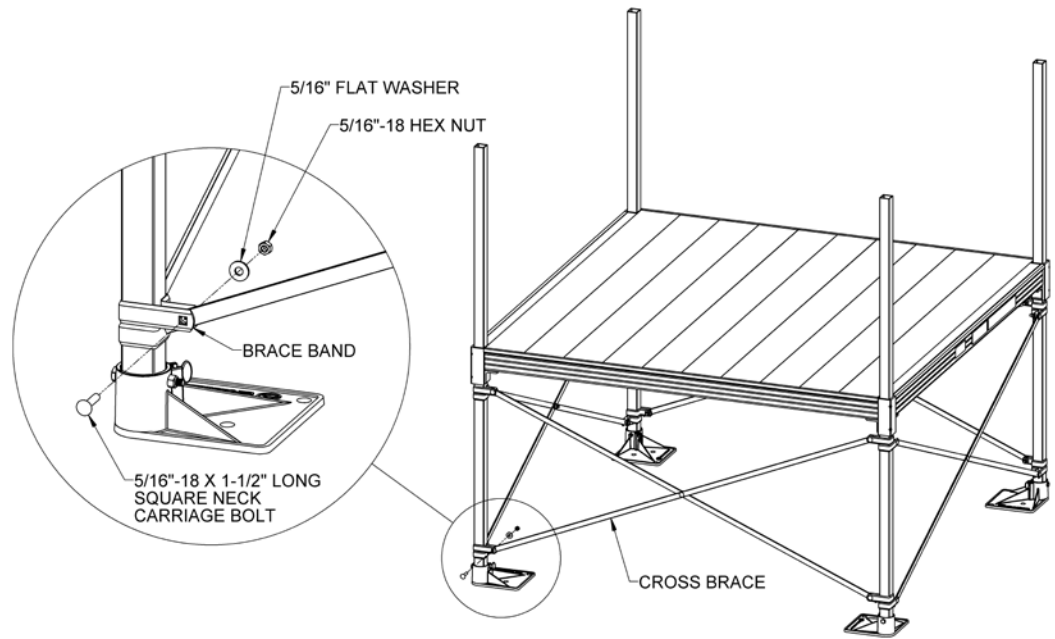

FIG. 7

- 1.12 If two platforms are used to create a turn-back, connect platforms using a Dual Platform Connector Kit.
- 1.12.1 On the first platform, install a dual platform connector on each of the two support tubes which will be adjacent to the second platform. Make sure that the pocket of the connector is oriented to the outside of the first platform, in the direction of the second platform and the setscrews are facing in a direction where they will be accessible (FIG. 8).
 - 1.12.2 Install legs and set the first platform at required height (as described in previous steps) except make sure the dual platform connector is installed on the support tubes in the correct orientation before bolting the feet.
 - 1.12.3 Bring both connectors up until they touch the bottoms of the corner pockets in the first platform and tighten the setscrews on the first platform side of the connectors securely (FIG. 9).
 - 1.12.4 On the second platform install the two legs which will be opposite the first platform and set them to the same height as the first platform then set the two open corner pockets of the second platform on top of the platform connectors and align the holes (FIG. 9).
 - 1.12.5 Install two 1-1/2" square x 36" long tubes through platform corner pockets and connectors until it aligns with bottom of connector and tighten all remaining setscrews securely (FIG. 10).

FIG. 8

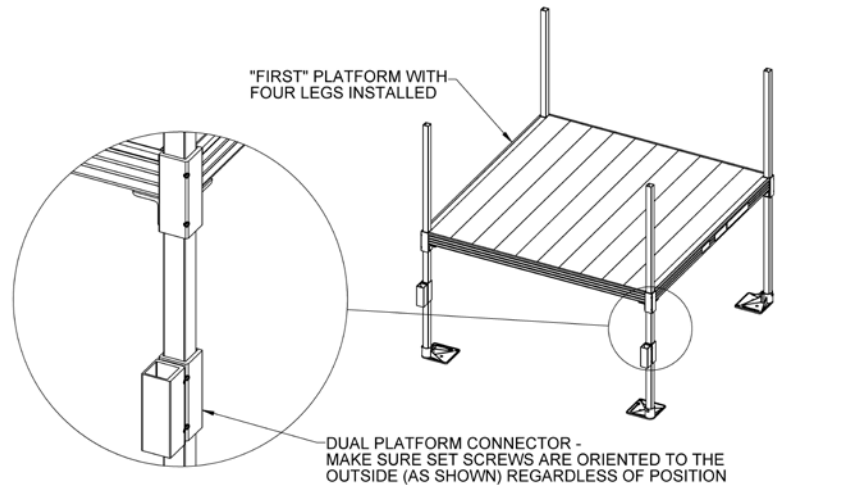
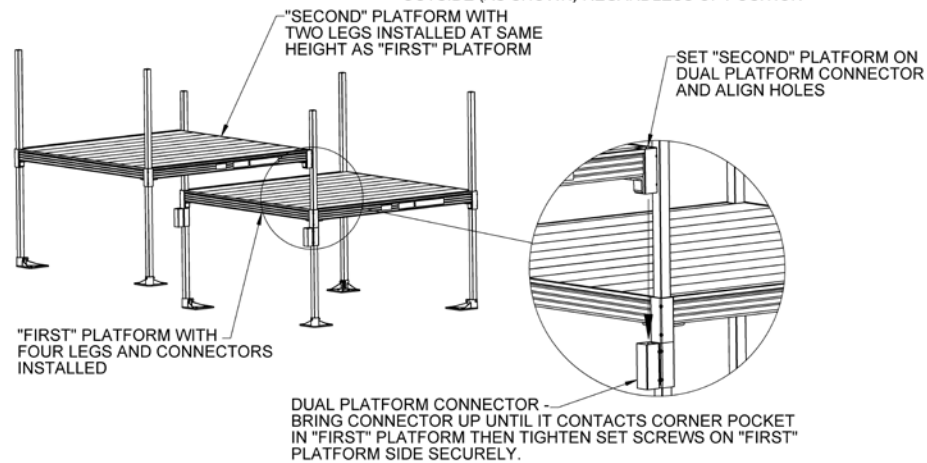

FIG. 9



- 1.13 Platforms can be combined, in any direction, to create a deck as long as the adjacent sides are the same length. The initial steps are similar to Sec. 1.12, using two platforms to create a turn-back. Refer to the project drawings for specific deck configuration.
- 1.13.1 On the first platform, install a dual platform connector on each of the two legs that will be adjacent to the second platform. Make sure that the pocket of the connector is oriented to the outside of the first platform in the direction of the second platform and that the setscrews are facing in a direction where they will be accessible (FIG. 8).
- ✎ Usually the uppermost platforms will be used to create a deck but this may not always be the case. Since the first platform is the one that sets the height for the rest, it is strongly recommended that the first platform be located at a door, or other fixed point where height is critical, regardless of its position in the deck.
- 1.13.1.1 If more than one platform is connected to the "first" platform, install a dual platform connector on the remaining legs as needed. Planning is required before installing the support tubes in the platform to make sure not only that the connectors are oriented in the right direction, but also that the subsequent platforms are supported by at least two legs as the deck is assembled (Refer to Section 1.13.8 for other requirements).
- 1.13.2 Install the legs and set the first platform at the required height as described in the previous steps.
- 1.13.3 Bring all connectors up until they touch the bottoms of the corner pockets in the first platform and tighten the setscrews securely (FIG. 8).
- 1.13.4 On the second platform (and all subsequent platforms), install the two legs that will be opposite the first (previous) platform and set to the same height as the first platform, then set the two corner pockets of the second platform on top of the platform connectors in the first platform (FIG. 9).

- 1.13.4.1 Same as the first platform, if more than one platform is connected to the “second” platform, install a dual platform connector on additional support tubes as needed, bring the connectors up until they touch the bottoms of the corner pockets and tighten all setscrews securely. Planning will be required to make sure not only that the connectors are oriented in the correct direction, but also that the subsequent platforms are supported by at least two legs as the deck is assembled, before installing the legs in the platform (Refer to Section 1.13.8 for other requirements).
- 1.13.5 If the platform connector is in a location where a guard, filler section or corner post (typically the outer edge of the deck) is required, install the 1-1/2” square x 35-1/2” long tube provided through the platform corner pocket and connector until it aligns (approximately) with the bottom of the connector and tighten all setscrews securely (FIG. 10).
- ✎ Installation of platform guards and other components is described elsewhere in the manual.
- 1.13.6 In all locations where there will be no guards or filler sections install the 1-1/2” square x 10-1/8” long tube provided through the platform corner pocket and connector. Center the stub (approximately) between the bottom of the connector and the platform walking surface making sure all the setscrews contact the stub and tighten setscrews securely (FIG. 10).
- 1.13.7 At this point there will be one or more support tubes extending above the platform deck which will **not** be used to attach a guard, filler section or corner post. Mark these support tubes at the top of the corner pocket and cut the leg off at or slightly below the mark (FIG. 11).
- ✎ The appearance and quality of the cut is not critical since these areas will be covered with a plate in later steps. What is critical is the support tube not stick up past the deck far enough to interfere with the plate when it is installed.
- 1.13.8 Add additional platforms by repeating steps 1.13.4 thru 1.13.7 until deck is complete.
- ⚠ The requirements below must be followed regardless of platform’s position in the deck.
- 1.13.8.1 There should always be one leg and one “stub” in a dual platform connector. This may require repositioning a connector from the way it was initially oriented (or replacing a stub with a support tube) depending on the configuration.
- ✎⚠ Never use two “stubs” without a leg in a dual platform connector.
- 1.13.8.2 Where four platforms come together, the two legs should be oriented so that they are diagonally opposite from each other (FIG. 12).
- 1.13.8.3 Whenever possible, especially where four platforms come together, the dual platform connector on one side of a platform should be oriented in the opposite direction from the other side and the orientation should then be alternated as the deck is created (FIG. 14).
- 1.13.8.4 Regardless of connector orientation, make sure there is a minimum of two legs installed in each platform’s corner pockets (FIG. 15).
- 1.13.9 Once the deck is complete all areas where platforms connect that are not used to attach a guard, filler section or corner post must be covered with a Corner Cover Plate (FIG. 13).
- 1.13.9.1 Use the corner cover plate provided to mark the location of the hole in the deck and drill four holes between 0.129” and 0.133” dia. (#30 drill).
- 1.13.9.2 Use the four 1/8” dia. rivets provided to attach the corner cover plate.
- 1.13.9.3 Use two cover plates where four platforms come together.

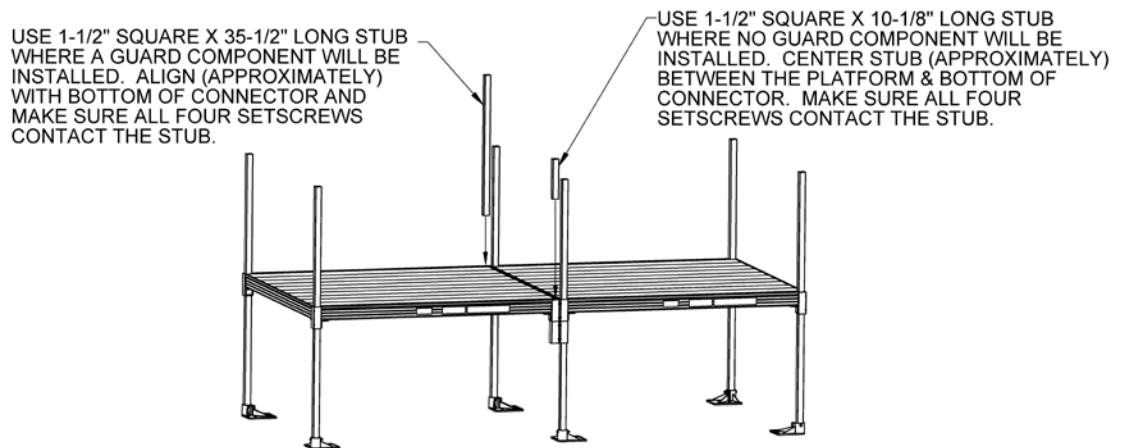

FIG. 10

FIG. 11

CUT EXCESS SUPPORT TUBE AT OR BELOW PLATFORM SURFACE WHERE NO GUARD COMPONENT WILL BE INSTALLED

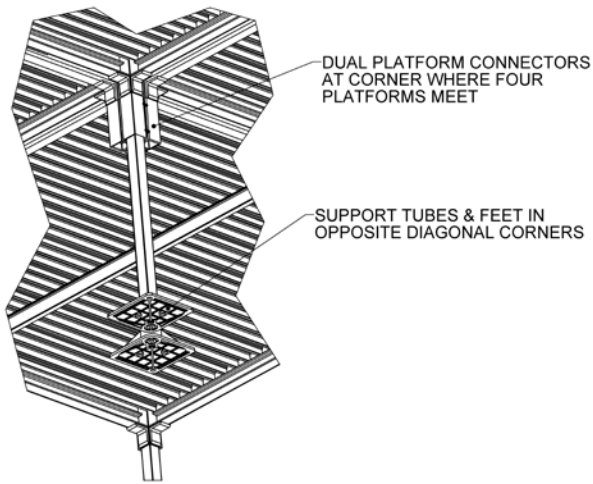
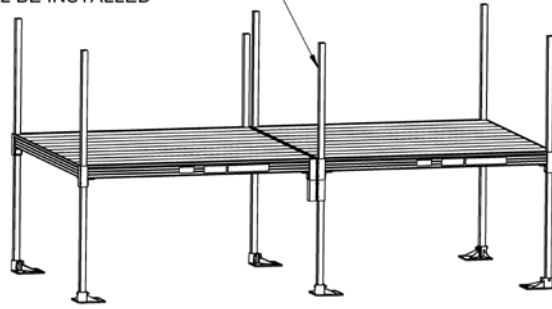

FIG. 12

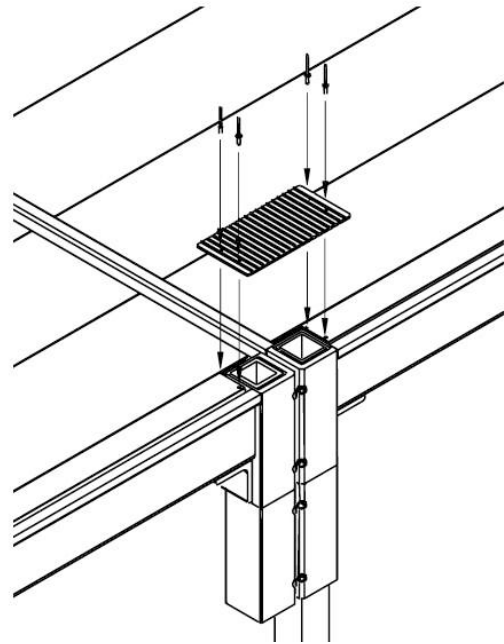

FIG. 13

FIG. 14

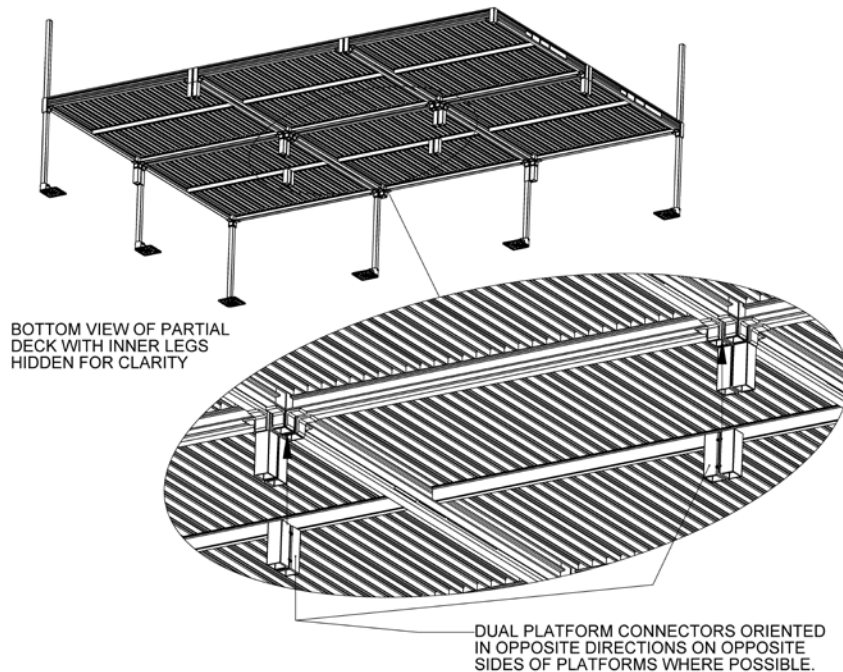
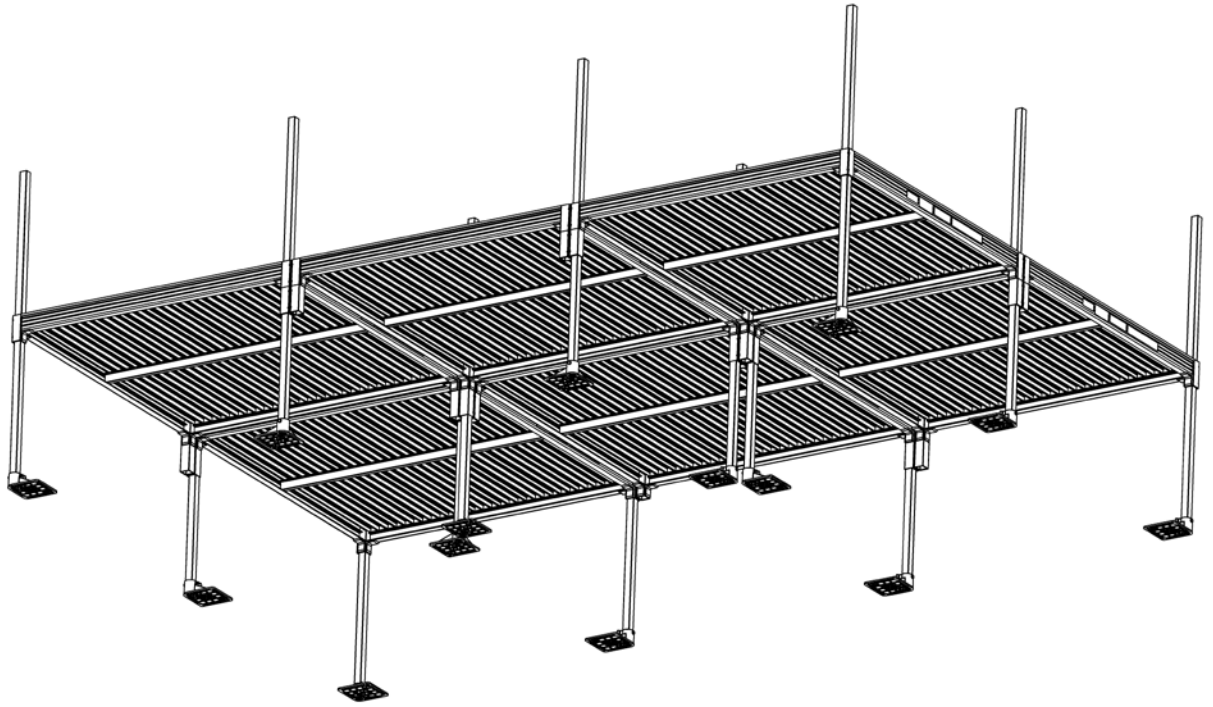

FIG. 15



BOTTOM VIEW OF PARTIAL DECK SHOWING A MINIMUM OF TWO LEGS PER PLATFORM AND INNER LEGS IN OPPOSITE CORNERS ON OPPOSITE SIDES

2. ASSEMBLE/SET RAMPS:

Five standard ramp lengths are available, 2', 3', 4', 5', and 6'. The standard starter ramp is 6' long. Ramps are also available in 48" and 54" widths (clear width between curbs). Consult manufacturer for custom sizes.

- 2.1 Begin setting ramps with the uppermost ramps in the system.
- 2.2 There are three different bracket types used to assemble ramp sections (see FIG. 16a, FIG. 16b and FIG. 16c). All three bracket types are fit into the side rail of the ramp section and are best installed with the ramp section placed upside down using the 5/16-18" x 1.5" hex bolts and washers. Make sure the narrow edge of the bracket engages the trough formed in the ramp section side rail and the holes in the bracket align with the threaded inserts preinstalled in the ramp section side rails. Use 1/2" wrench or socket to secure fasteners.
 - 2.2.1 End support assembly bracket (FIG. 16a): These brackets come in a left and right pair and attach to the upper and lower end of a ramp run to support the ends of the ramp run when combined with support legs. These brackets also provide attachment points for the guardrails.
 - 2.2.2 Guard brackets (FIG. 16b): This pair of brackets provides an attachment point for the guardrails at the mid-point of a ramp section.
 - 2.2.3 Center support assembly bracket (FIG. 16c): This pair of brackets joins ramp sections together and is required where ramp sections meet in a ramp run. They support the ramp at this point when combined with support legs and provide attachment points for the guardrails.

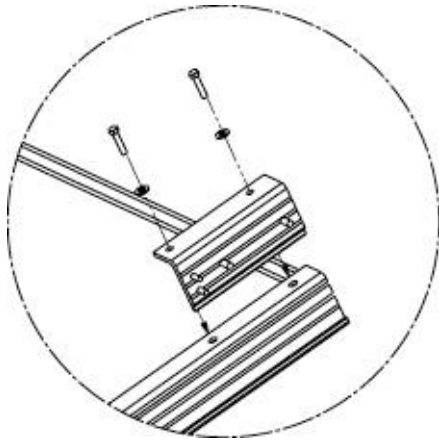

FIG. 16a

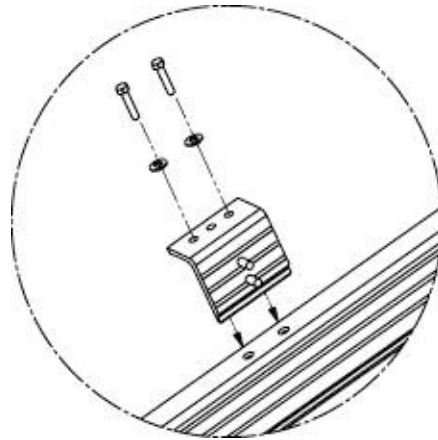

FIG. 16b

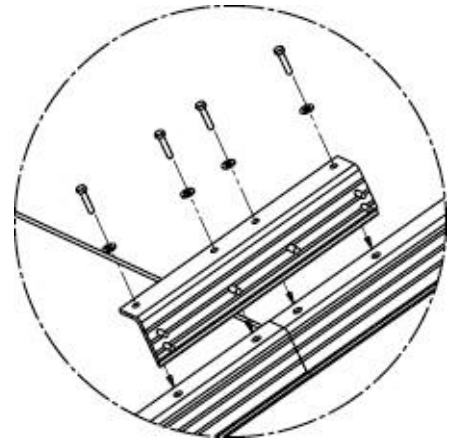

FIG. 16c

- 2.3 If using a single ramp as the first upper section:
 - 2.3.1 Lay the ramp section upside down.
 - 2.3.2 Install end support assembly brackets (FIG. 16a) at both ends of the ramp section. This will require two pairs of end support brackets.
 - ⚠ Make sure that the two larger diameter studs protruding from the brackets are positioned toward the outer end of the ramp section.
 - 2.3.3 Install one pair of guard brackets (FIG. 16b) at mid-point of ramp section in similar manner.
- 2.4 If using two or more ramp sections for uppermost ramp run:
 - 2.4.1 Lay ramp section end-to-end upside down on a level surface (a level surface will make sections easier to connect).
 - 2.4.2 Install one pair of center support brackets (FIG. 16c) at each junction of two ramp sections.
 - ⚠ It is critical that the center support bracket be positioned equally with respect to threaded inserts in the ramp sections to avoid problems aligning the guards and handrails later. This may require measuring. There is a centering mark on the support bracket to assist with this process.

- 2.4.3 Install end support assembly brackets (FIG. 16a) at both ends of the ramp run (this will require two pairs of end support brackets).
 - 👉 Make sure that the two larger diameter studs protruding from the brackets are positioned toward the outer end of the ramp section.
- 2.4.4 Install one pair of guard brackets (FIG. 16b) at the mid-point of each ramp section making up the run.
- 2.5 If using as a turn or turn-back:
 - 2.5.1 Ramp must be positioned to one side or the other of the platform and should always be positioned to the outside of the turn.
 - 2.5.2 Position the ramp to one side of the platform so that the edge of the transition plate is 4½" from the outer edge of the platform (FIG. 17).
 - 👉 The transition plate will be secured to the platform later in the assembly process.
- 2.6 If the system requires an intermediate "resting" platform, the ramps must be positioned in the center of the platform (see FIG. 28 and FIG. 32).
- 2.7 Repeat this procedure when assembling and setting ramp runs until the lowest run is reached.
- 2.8 The lowermost ramp section (the only section that contacts the ground directly) is called the starter ramp section. This section can be identified by the taper at one end of the ramp.
 - 2.8.1 The underside of the taper will sit directly on the ground so an end support assembly is not required.
 - 2.8.2 Install (1) pair guard brackets (FIG 16b) at mid-point of ramp section and either an end support assembly, if the starter section is the only ramp in the run, or a center support assembly if connecting to another ramp section as described in previous steps.

3. INSTALLING TRANSITION PLATE(S)

- 3.1 A transition plate is required at any point that a ramp section or ramp run meets a platform.
- 3.2 Install a transition plate into each end of the ramp section(s) by turning the section(s) over, then inserting as shown in FIG. 18.
- 3.3 Position ramp section so the transition plate is fully supported by the platform surface as shown in FIG. 19. Make sure that the top transition plate overlaps the supporting surface as far as possible.
 - 👉 The transition plates may not rest flat on platform at this point and this is normal (transition plates will be secured later, as shown in FIG. 48).

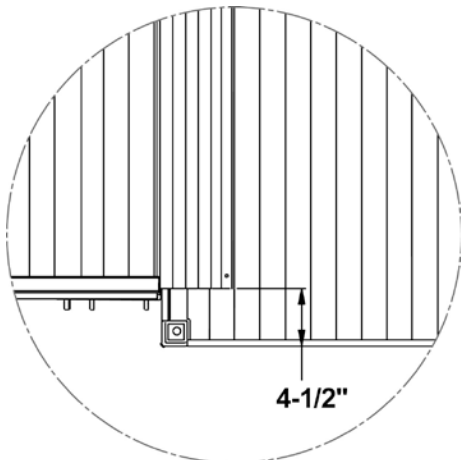

FIG. 17

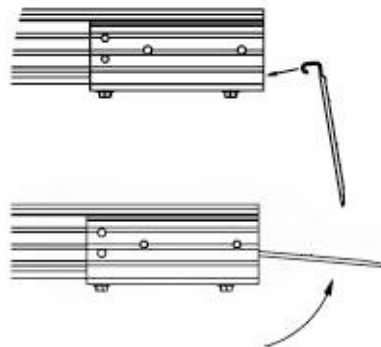

FIG. 18

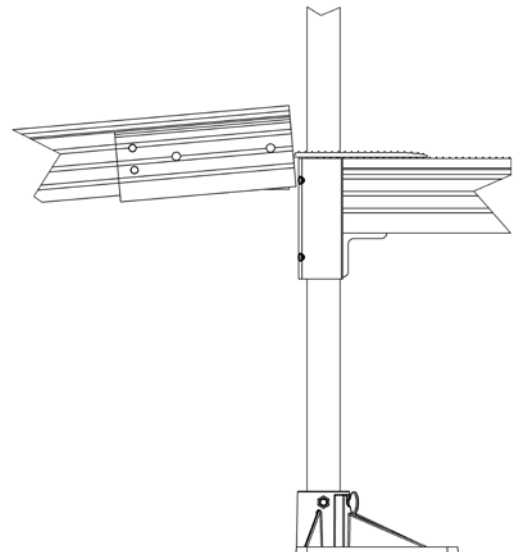

FIG. 19

4. INSTALLING SUPPORT TUBES (LEGS) TO RAMP SECTION(S):

- 4.1 Install universal support tube brackets to the support assembly brackets with the 3/8" studs extending through the curved slots in the support tube brackets. Use two 3/8"-16 nylon insert locknuts and 3/8" washers at each location but do not tighten fully (FIG. 20).
- 4.2 Beginning at the upper end of the ramp system, loosen the set screws in the support tube brackets as needed and install the support tubes through the support tube brackets into the polymer foot. Make sure the correct support tube is used for the location in the system and position the foot so it extends beneath the ramp.
- 4.3 Cut support tubes (legs) to approximately 2" above the support tube bracket (FIG. 21).
 🖐️ Ramp support tubes (legs) should extend at least 1" but no more than 2-1/4" above the support tube bracket to avoid interference with the guards.
- 4.4 Use the hole in the foot as a template to drill 11/32" or 3/8" hole through the support tube.
- 4.5 Install a 5/16"-18 x 3" long hex bolt through the support tube and foot then secure with the 5/16"-18 nylon insert locknut and tighten the thumb screw securely.

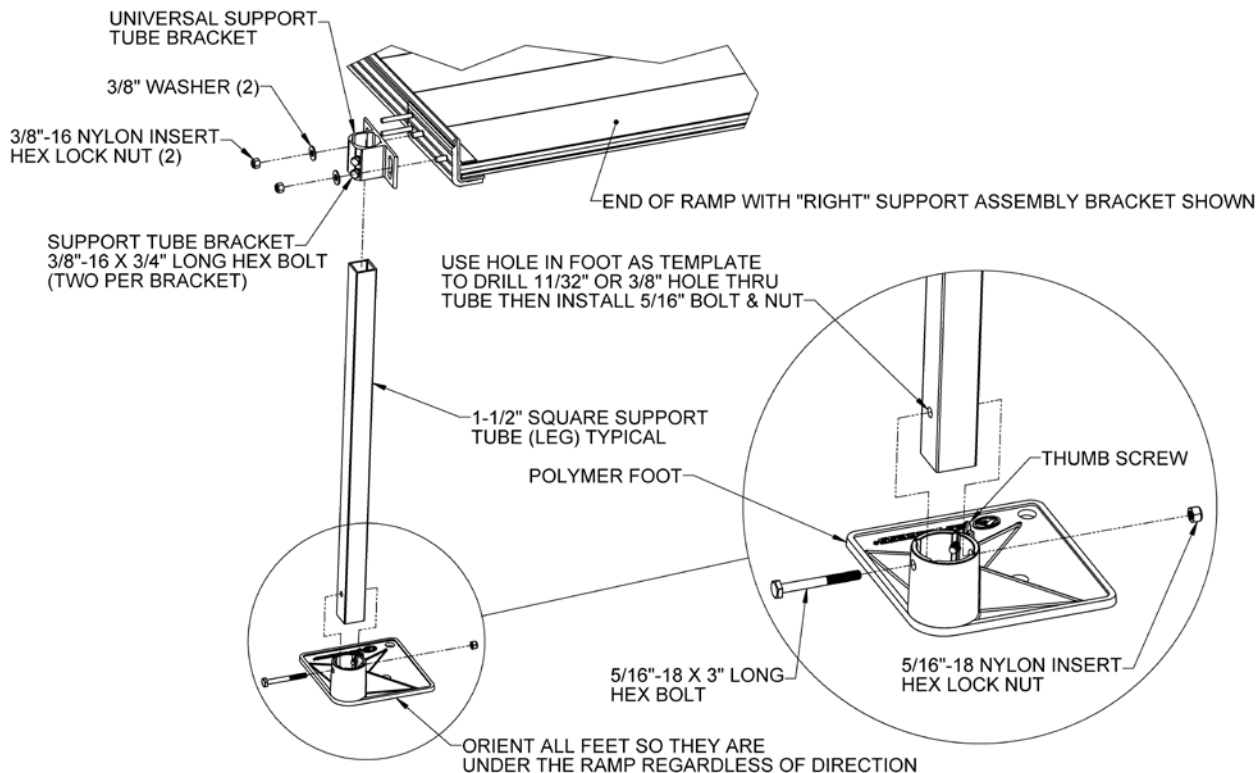

FIG. 20

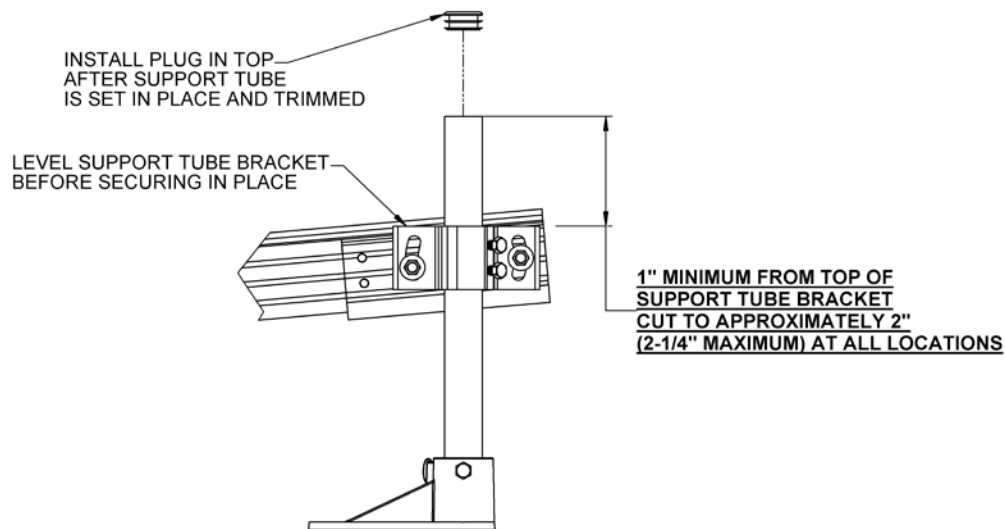
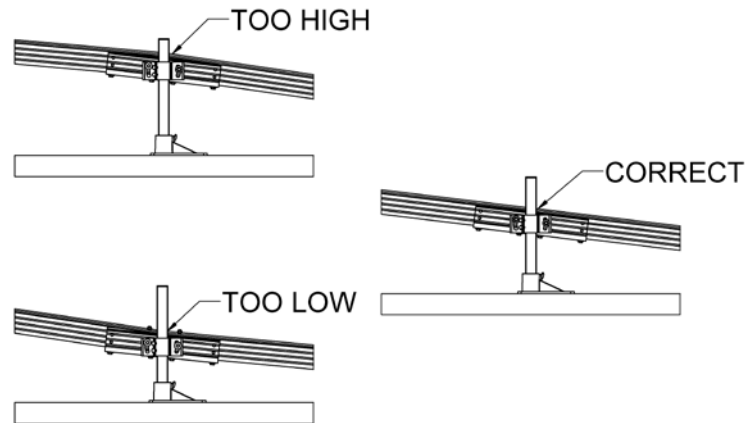

FIG. 21

- 4.6 Level the universal support tube brackets and secure in level position using a 9/16" wrench.
- 4.7 Adjust the ramp height until the transition plate is resting flat on the platform surface. Tighten both set screws in the universal support tube bracket securely then repeat process on the opposite side of the ramp.
- 4.8 Repeat the process on the lower end of the ramp or ramp run, again insuring that the transition plate rests flat on the platform surface.
- 4.9 Use same procedure to install the support tubes (legs) and feet on the center support brackets if present.
- 4.10 Have a helper site down the top edge of the ramp side rail and adjust ramp height where the ramps connect until top edge of ramp side rails are aligned then tighten the set screws in the support tube brackets securely.
 - ✋ It is important that the support tubes (legs) are adjusted correctly and the ramp sections are aligned, neither bowing down or up (see FIG. 22 for correct positioning). Failure to adjust properly will result in difficulty attaching the ramp guards and handrails later in the assembly.
- 4.11 Repeat this procedure when assembling and placing ramp section(s) between platforms until the lowest section is reached.

FIG. 22



- 4.12 The lowest ramp run will always begin with a starter section. This section requires the same installation procedure with two exceptions.
 - 4.12.1 There is no end support assembly on the tapered end of the ramp section and, since it rests on the ground, no support leg is required.
 - 4.12.2 Only one transition plate is required at the top of the ramp run.
- 4.13 Install plugs in the top of all support legs.
- 4.14 Ramps over three feet high from the ground require cross bracing.
 - 4.14.1 Insert legs into the ramp and set ramp at the required height as described in previous steps.
 - 4.14.2 Assemble the cross brace using the 5/16"-18 x 1-1/2" long hex bolt, nylon insert locknut and washer through the center hole in both braces.
 - 4.14.3 Separate the ends of brace bands until they go around the 1-1/2" square tube and install two bands on each leg. Orient the bands so that the side with the holes extends under the ramp (FIG. 23).
 - 4.14.4 The brace assembly should be placed approximately in the middle of the ramp legs with the top brace bands as far as practical from the bottom brace bands, but a minimum of 24", and the brace assembly under the ramp.
 - 4.14.4.1 If needed for the location, trim the ends of the brace assembly to fit. Remove all sharp edges after cutting with a file or by sanding.
 - 4.14.5 If the ends with the pre-drilled holes are cut to fit the location, drill an 11/32" or 3/8" diameter hole on center approximately 3/8" to 1/2" from the end of each brace.
 - 4.14.6 Install brace assembly using four 5/16"-18 x 1-1/2" long carriage bolts, nuts and washers in the desired location (FIG. 23).
 - 4.14.7 Tighten all fasteners securely.

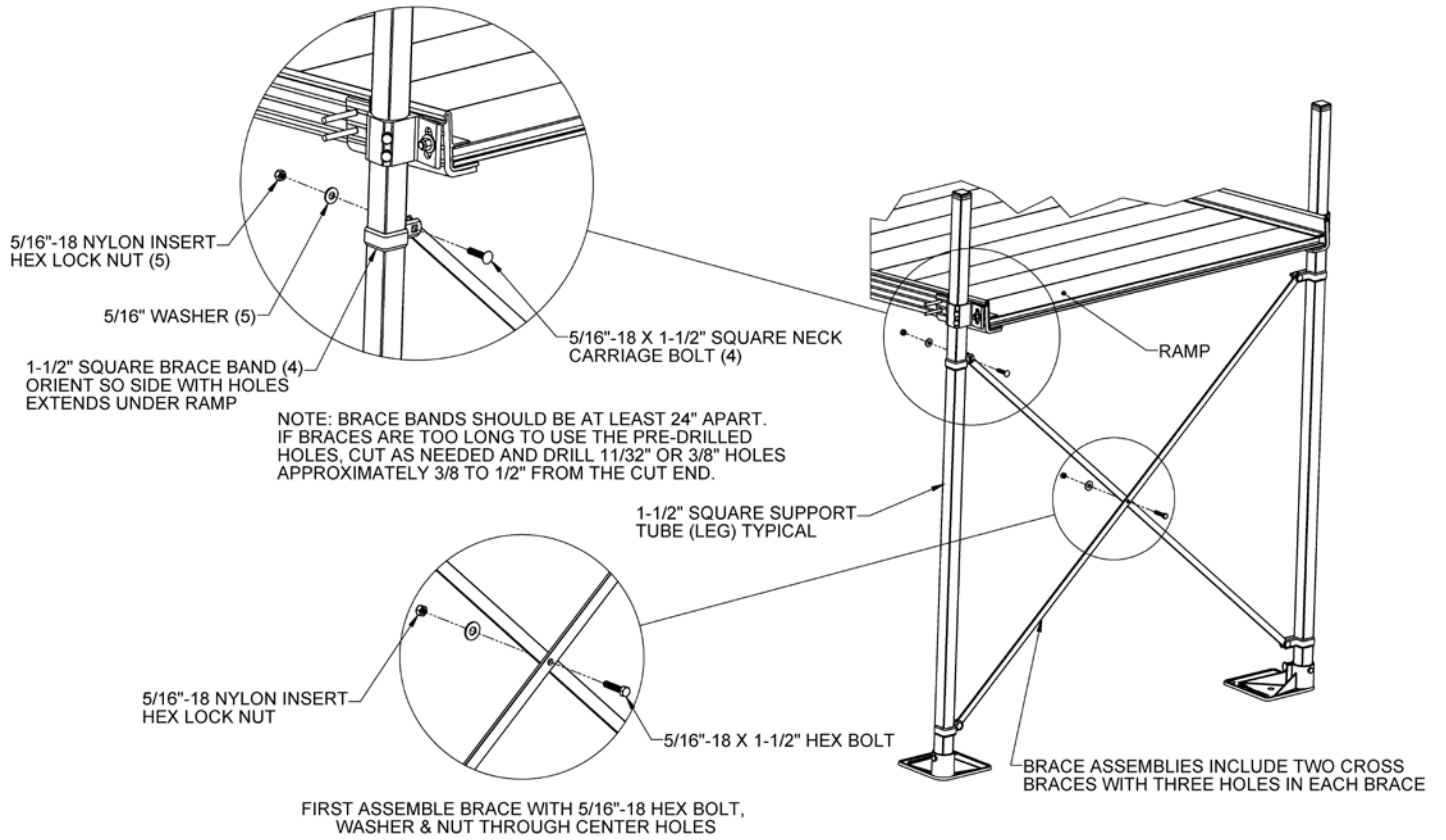

FIG. 23

5. INSTALLING PLATFORM GUARDS:

5.1 Depending on the system configuration, following are four platform guardrail component options that may be used that may be used in different combinations:

- ① Five-foot, six-foot and seven-foot guard sections (FIG. 24a)
- ② Guard corner post (FIG. 24b)
- ③ Guard filler sections for five-foot, six-foot and seven-foot platforms (FIG. 24c)
- ④ Guard corner sections for five-foot and six-foot platforms (FIG. 24d)

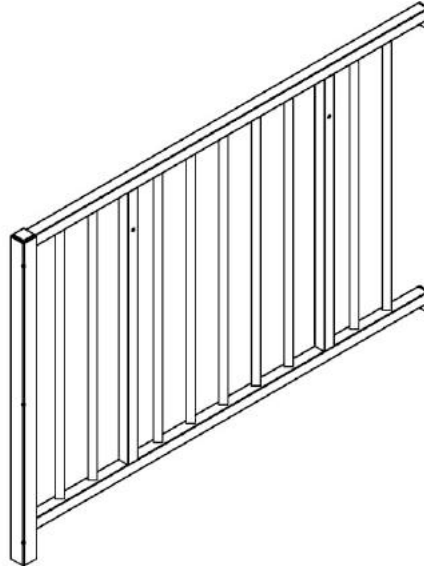

FIG. 24a



FIG. 24b

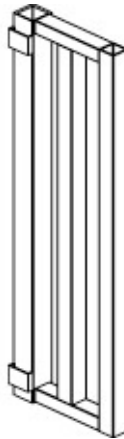

FIG. 24c

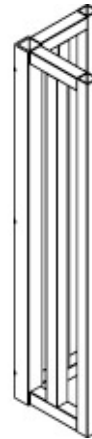

FIG. 24d

5.2 There are three basic platform arrangements: turn, turn-back, and straight through. The straight through arrangement is different at a top landing and a “resting” platform so both are covered in this section. Many other platform arrangements are possible when combined into decks, but the following guard installation instructions cover all common installations regardless of the size or shape of the deck. Select the appropriate platform arrangement and install the guards as shown in FIG. 25 through FIG. 34.

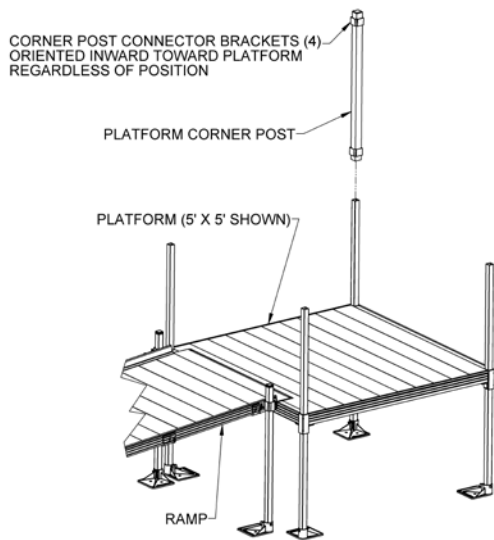

FIG. 25

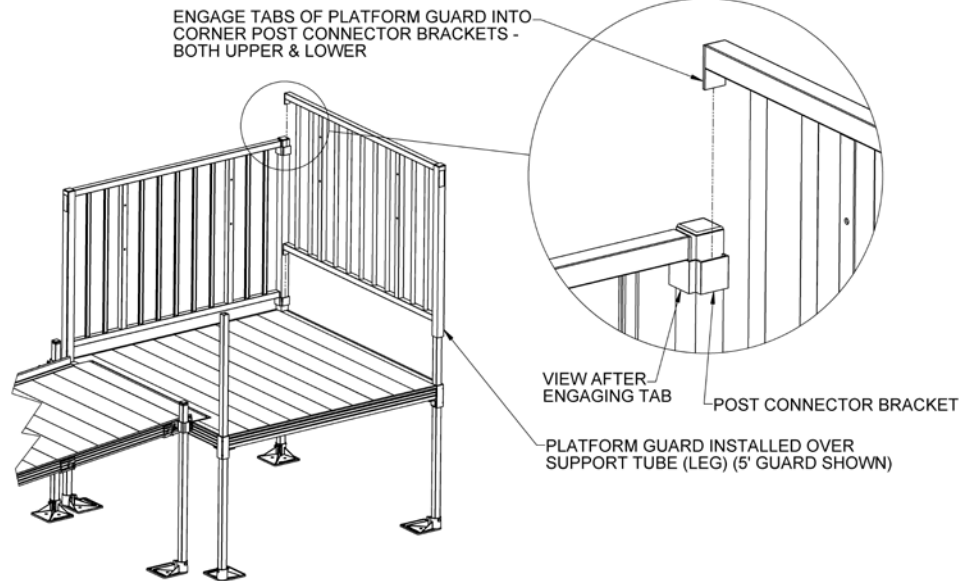
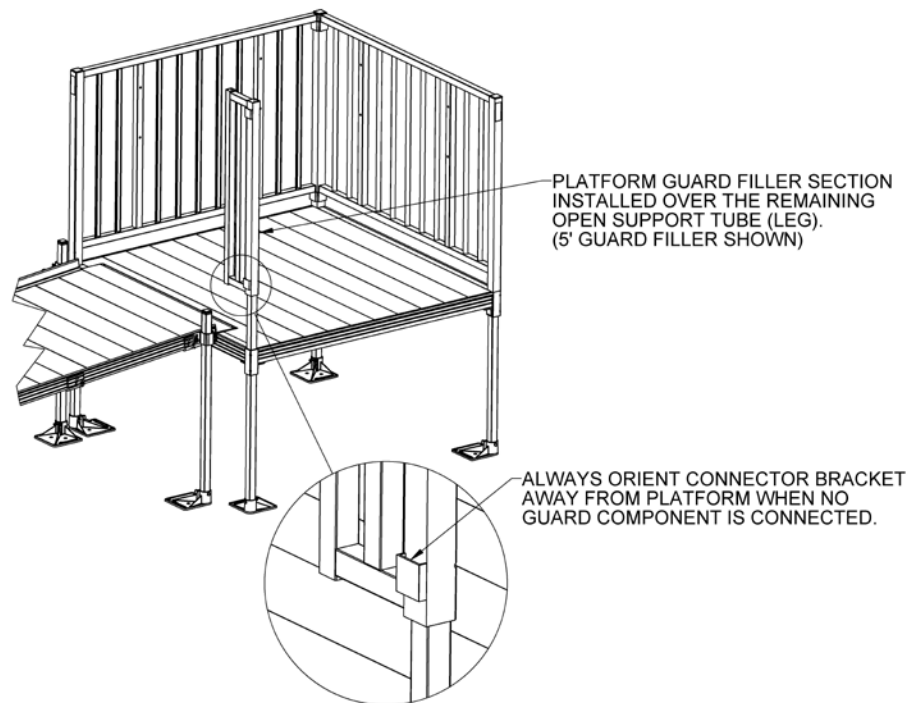

FIG. 26

FIG. 27



- 5.3 If a single platform is used as a landing at the top of the system with the ramp approach parallel to the door:
- 5.3.1 Place one guard corner post over the support tube (leg) extending out of the platform corner pocket opposite both the door and ramp (FIG. 25). Do not tighten set screws.
 🖐️ All four connector brackets should be oriented in toward the platform.
 - 5.3.2 Place two guards over the support tubes (legs) protruding out of the platform corner pockets opposite the corner post connector brackets (FIG. 26) and engage tabs on the guard sections into connector brackets on corner post. Do not tighten set screws.
 - 5.3.3 Place guard filler section over the remaining support leg with the connector brackets oriented toward the outside of the platform (FIG. 27).

- 5.4 If a single platform is used as a landing at the top of the system with the ramp approach at 90 degrees to the door:
- 5.4.1 Place one guard corner post over the support tube (leg) extending out of the platform corner pocket adjacent to the door and opposite ramp. Two of the corner post connector brackets should be oriented toward the support tube where the guard will attach and the other two away from the platform (FIG. 28). Do not tighten set screws.
 - ✋ Unused connector brackets should always be oriented away from the platform.
 - 5.4.2 Place a guard over the support tube (leg) opposite the corner post connector brackets and engage tabs on the guard into connector brackets on corner post (FIG. 28). Refer to detail in Fig. 26 for engaging tab in connector bracket. Do not tighten set screws.
 - 5.4.3 Place guard filler section over the other support leg on the ramp side with the connector brackets oriented toward the platform (FIG. 29).
 - 5.4.4 Place a guard over the remaining support tube (leg) and engage tabs on the guard into connector brackets on guard filler section (FIG. 29).

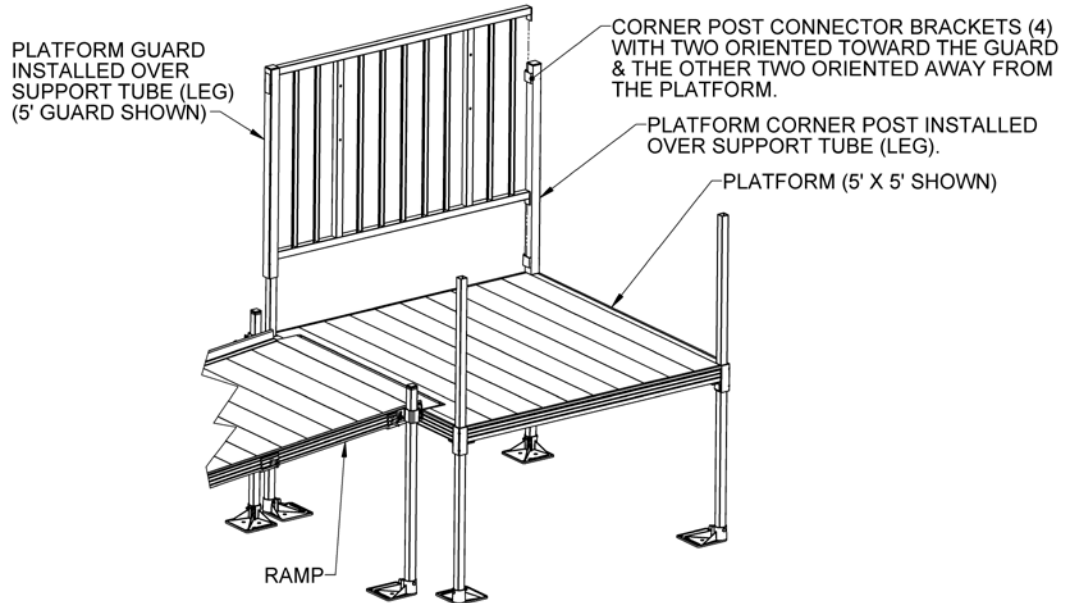

FIG. 28

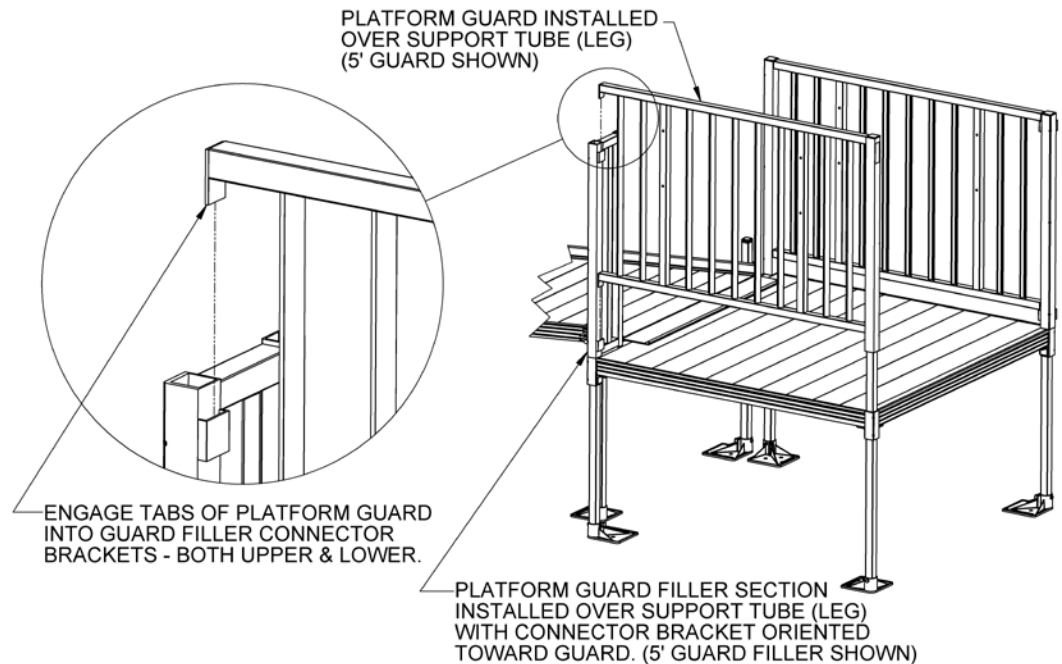

FIG. 29

- 5.5 If platforms are used to create a turn back (or switchback):
 - 5.5.1 Both platforms will use the same guard components and follow the same steps as in section 5.3 except one platform is the mirror image of the other (see FIG. 25, 26, 27 & 30).
- 5.6 If a platform is used in a 90 degree turn from one ramp to another ramp (FIG. 31):
 - 5.6.1 Install a guard corner post and two platform guards in the same manner as described in steps 5.3.1 and 5.3.2.
 - 5.6.2 Place guard corner section over the remaining support leg oriented as shown in Fig. 31.
- 5.7 If platform is used as a straight through resting platform (FIG. 32):
 - ☞ This method can only be used with a 5 ft. x 5 ft. platform; consult project drawings if using a platform other than a 5 ft. x 5 ft. platform as a resting platform.
 - 5.7.1 Place two guard posts over the support legs on one end of the platform where a ramp attaches. Two of the connector brackets on each corner post should be oriented toward the support tube where the guard will attach and the other two away from the platform.
 - ☞ Unused connector brackets should always be oriented away from the platform.
 - 5.7.2 Place two 5 ft. platform guards two over the other two support tubes (legs), making sure to engage tabs on platform guards into connector brackets on guard posts.
- 5.8 If platforms are being used to create a deck the entire outer edge of the deck must be guarded except where the platform is within 1/4" to 1/2" (maximum) of a wall.
 - 5.8.1 Installation of the guards at a corner is the same as the first two steps of section 5.3. Refer to FIG. 25 and FIG. 26.
 - 5.8.2 Installation of the guards on a side is the same as the first two steps of section 5.4 Refer to FIG. 28.
 - 5.8.3 Guard filler sections can also be used close gaps where a full length guard is not needed. Consult project drawings where applicable.
- 5.9 Tighten the lower two 3/8"-16 setscrews in **all** of the vertical guard posts with a 3/16" hex key wrench securely (FIG. 33).
 - ☞ The two lower set screws should contact the support tube (leg). If the middle set screw does not, confirm the length of the support tube is correct for the location and replace if needed.
- 5.10 Install plugs in the top of all open guard posts.

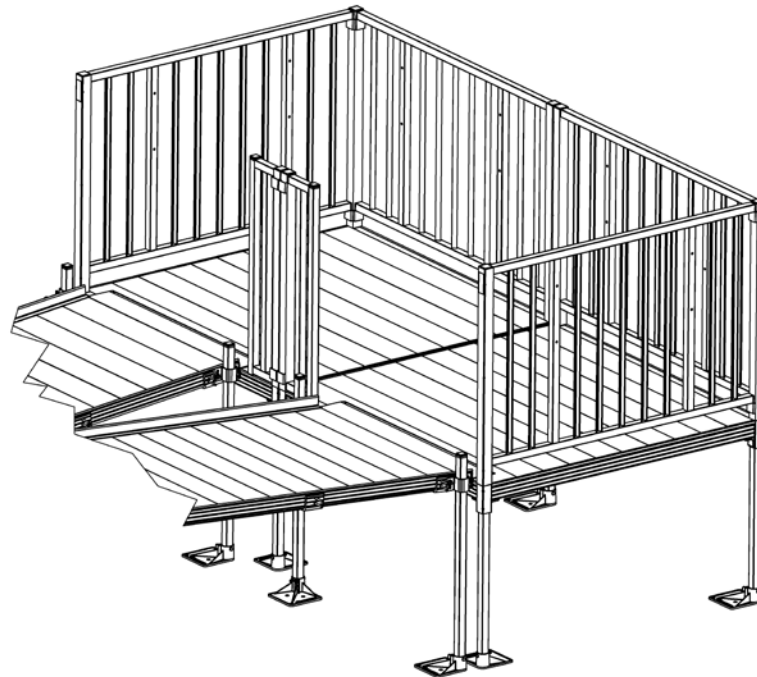
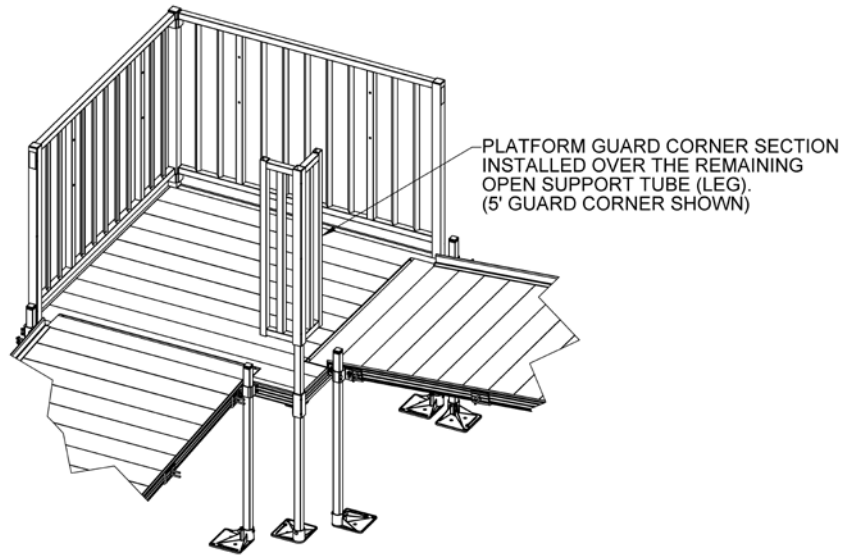

FIG. 30

TWO PLATFORMS WITH GUARDS, GUARD FILLER SECTIONS & RAMPS IN A TURN BACK CONFIGURATION. (5' X 5' PLATFORMS & 5' GUARD COMPONENTS SHOWN)

FIG. 31



PLATFORM WITH GUARDS, GUARD CORNER SECTION &
TWO RAMPS IN A TURN CONFIGURATION.
(5' X 5' PLATFORM & 5' GUARD COMPONENTS SHOWN)

FIG. 32

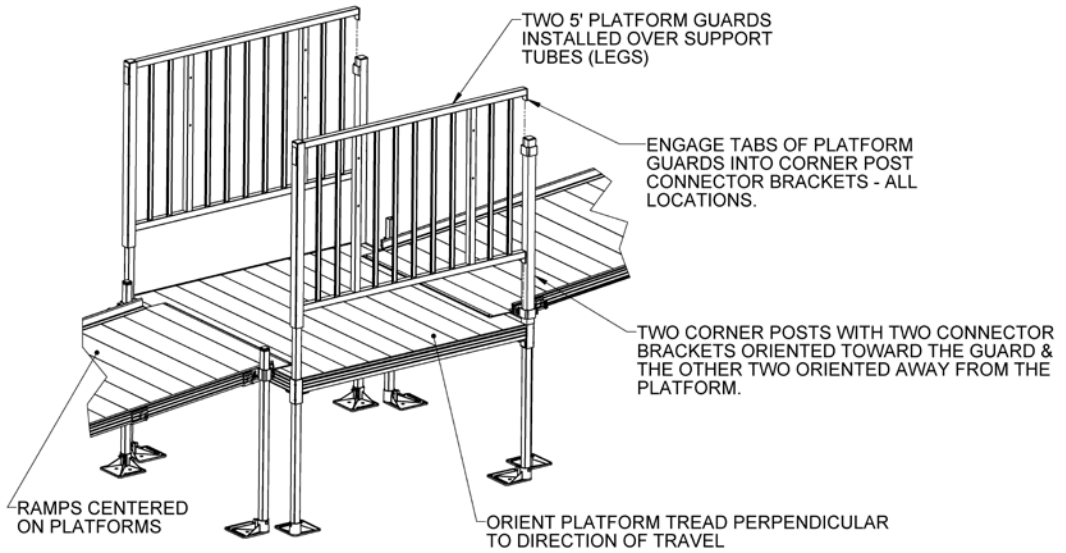

5' X 5' PLATFORM WITH GUARDS & RAMPS IN
A STRAIGHT THROUGH CONFIGURATION.

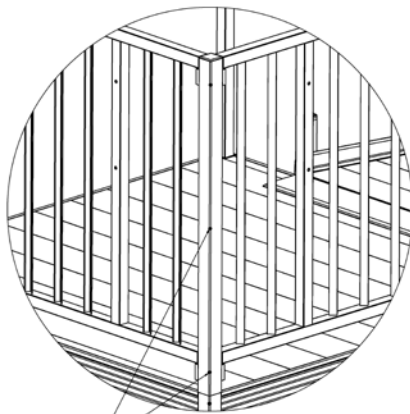

TIGHTEN THE TWO LOWER SETS CREWS IN EACH
CORNER POST, GUARD POST & GUARD FILLER POST.
NOTE: IF THE MIDDLE SET SCREW DOES NOT
CONTACT THE SUPPORT TUBE (LEG), CONFIRM THE
SUPPORT TUBE IS THE CORRECT LENGTH FOR THE
LOCATION AND REPLACE IF NEEDED.

FIG. 33

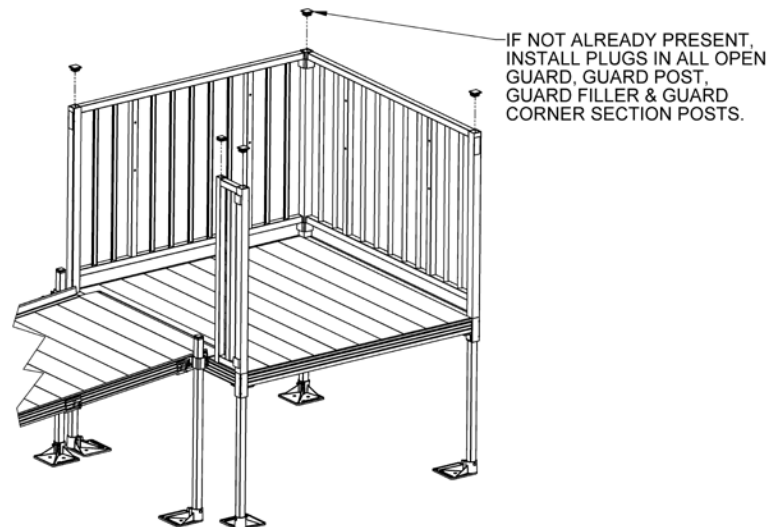
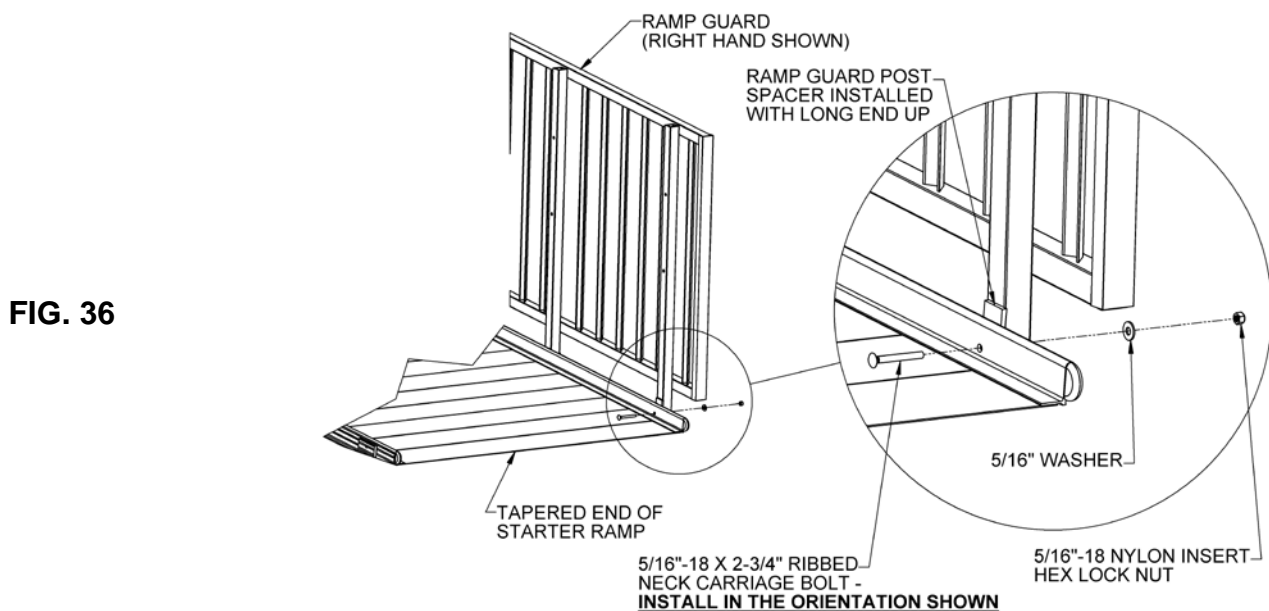
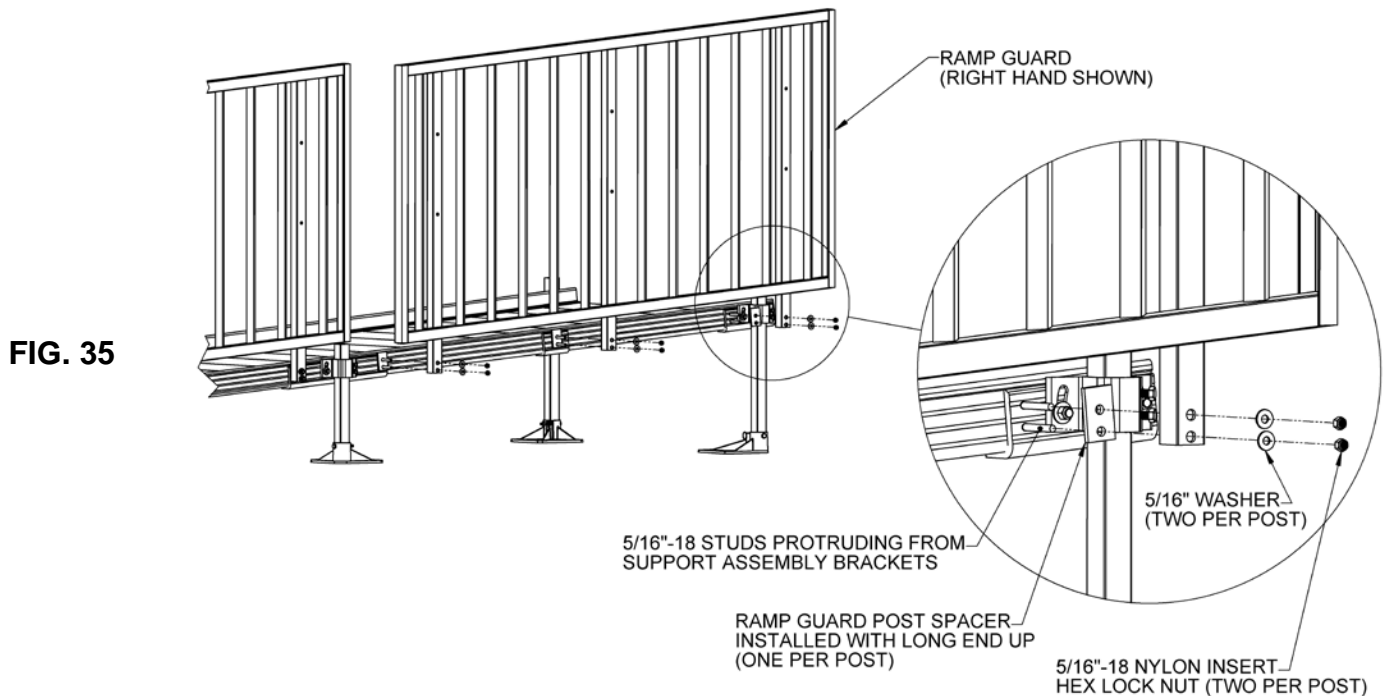

FIG. 34

6. INSTALLING RAMP GUARDS:

- 6.1 Ramp guards come in left and right pairs and are not interchangeable from side-to-side. For all ramp sections other than the starter section:
 - 6.1.1 Install the Ramp Guard Post Spacers over the 5/16"-18 studs protruding from the brackets previously installed on the ramp section with the long end of the spacer pointing up (FIG 35).
 - 6.1.2 Attach the ramp guard to the ramp section by positioning the lower holes in the ramp guard posts over the studs.
 - 6.1.3 Once the guard is in place, place a 5/16"-18 nuts and 5/16" flat washers on each stud. Take up play with the nuts but do not tighten (this will help with alignment during handrail installation).
- 6.2 For the starter section, two of the three guard vertical posts are installed in the same manner. Secure the lowermost post using a 5/16"-18" x 2 3/4" carriage bolt inserted thru the holes in the ramp side rail and secured with a 5/16"-18 nut and 5/16" flat washer (FIG 36).



7. INSTALLING HANDRAILS:

- 7.1 Ramp handrails are supplied in left and right pairs and are not interchangeable.
- 7.1.1 Starting at the lower end of ramp system, attach first handrail section by aligning holes in the handrail brackets with the holes in the guard vertical posts. Secure with one 5/16"-18 x 2 1/4" button head socket cap screw, washer and nylon insert lock nut as shown in FIG. 37 but do not tighten fully.
- 7.1.2 Repeat on the remaining handrail brackets securing bolts but not fully tightening.
- 7.1.3 Install handrails on opposite side in the same manner.
- 7.1.4 Install 4" joiner assembly to uphill end of the previously installed handrail section (FIG. 38), passing the next handrail section over the joiner assembly, then secure to guard in same manner as previous handrail.
- 👉 Joiner expansion screws should always be oriented to the underside of the handrail.
- 7.1.5 Continue until all ramp handrail sections are installed.
- 7.1.6 Once all handrails are connected tighten all fasteners connecting handrails to guards, as well as guards to ramps and joiners, securely.

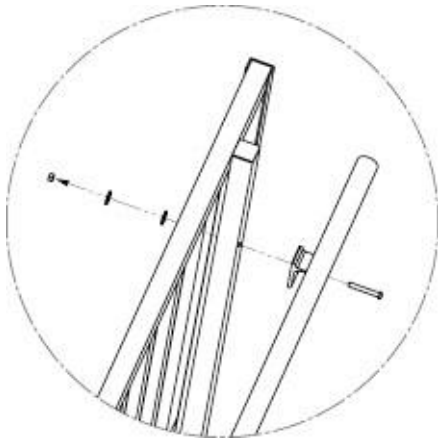

FIG. 37

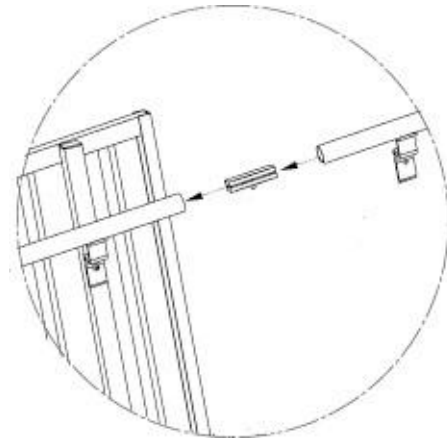

FIG. 38

8. INSTALLING HANDRAIL ATTACHMENTS:

- 8.1 There are five different handrail attachments that may be used in different combinations to finish the handrail installation:

- ① Lower loop (FIG. 39a)
 - ② Upper loop (FIG. 39b)
 - ③ 5-degree elbow (FIG. 39c)
 - ④ 90-degree elbows (FIG. 39d)
- 👉 90 degree elbow will require trimming to size. When using with a joiner, DO NOT trim more than 3/8" off the short leg of the 90 degree elbow as this will not allow the joiner to seat properly
- ⑤ Adjustable elbow (FIG. 39e)
 - ⑥ Dual termination loop (FIG. 39f)

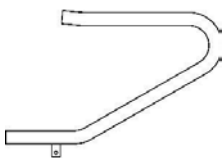

FIG. 39a

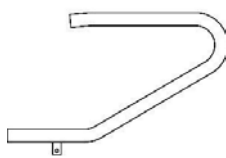

FIG. 39b



FIG. 39c



FIG. 39d



FIG. 39e

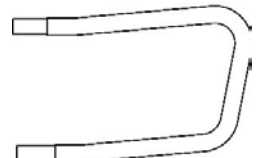

FIG. 39f

- 8.2 At the bottom of the ramp (i.e., the starter ramp at the ground or ramp runs starting at a resting platform), install two lower termination loops into the ends of each handrail (FIG. 40).
- 8.2.1 Install upper portion of loop to handrail using a 4" joiner. Tighten set screw enough to hold in place, but leave loose enough to rotate.
- 8.2.2 Rotate lower portion of loop until it lines up with ramp guard post. Mark center, then drill 5/16" or 11/32" hole through post. Secure lower end of loop with 5/16"-18 x 2" button head socket cap screw through the drilled hole and into threaded insert in lower end of loop.
- 8.2.3 Attach tab on bottom of loop by drilling a 5/16" or 11/32" hole through the channel at the end of the ramp guard and securing with a 5/16"-18 x 3" button head socket cap screw, three washers and nylon insert lock nut. Place nut and two washers on outside of ramp and place one washer between the head of the bolt and the tab on the loop.
- 8.2.4 Tighten all fasteners securely.
- 8.3 At a straight through resting platform or upper end of a ramp run where hand rails are not returned to platform guards (FIG. 40):
- 8.3.1 Install two upper loops at the top of the ramp and two lower loops at the start of the next run in the same manner as above.
- 👉 The only difference between the upper and lower loop installation is that the upper loop uses a 4" ring joiner instead of the standard 4" joiner.

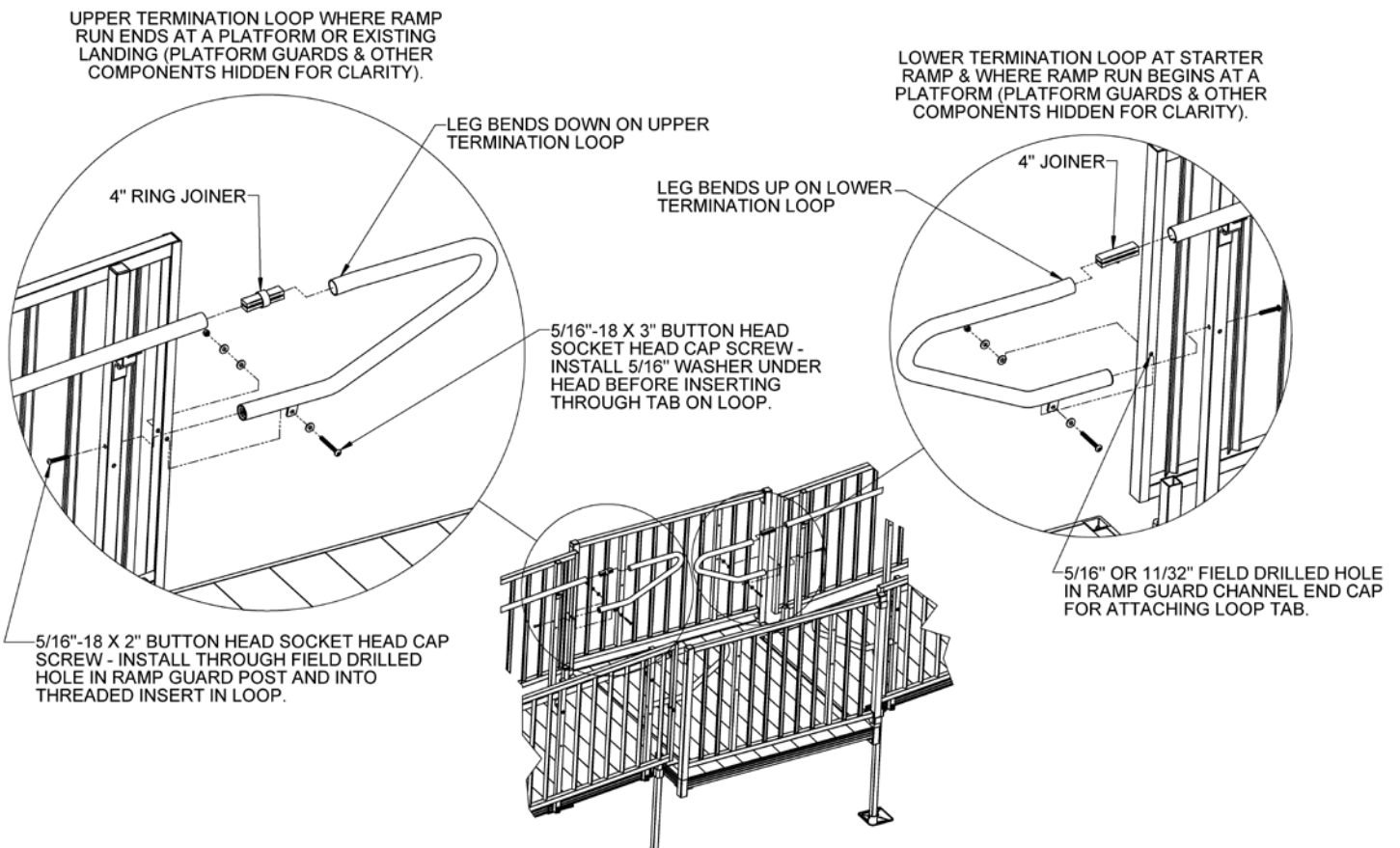

FIG. 40

- 8.4 At a turn platform on the outside, non-turn side (both where the top of a ramp meets a platform and where a ramp starts at a platform) as shown in FIG. 41:
- 8.4.1 Use a ring joiner to attach one 5 degree elbow to ramp handrail.
 - 8.4.2 Hold 90 degree elbow in position and mark for trimming.
 - 8.4.3 After trimming, test fit elbow.
 - 8.4.4 When fit is confirmed, install threaded insert into short end of elbow with a hammer.
 - 8.4.5 Connect long side to 5 degree elbow with a ring joiner.
 - 8.4.6 Connect short end to vertical tube on guard with 5/16"-18 x 2" button head screw.
 - 8.4.7 Tighten all fasteners securely.

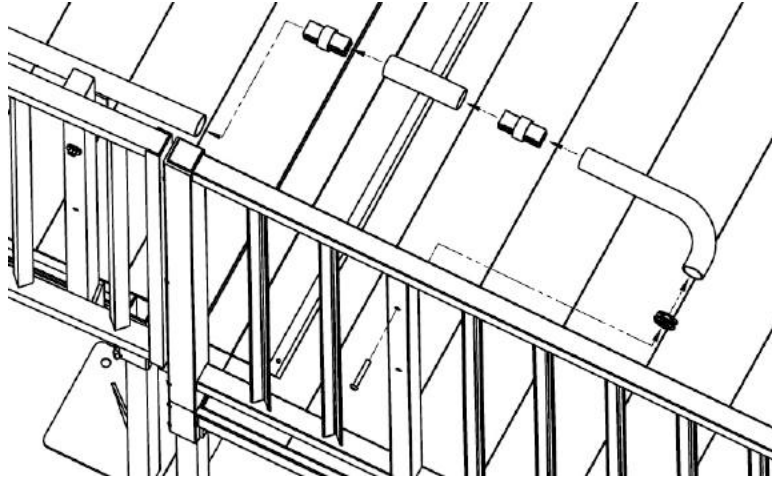

FIG. 41

- 8.5 At a turn platform at top of system on inside turn side (FIG. 42):
- 8.5.1 Hold 90 degree elbow and handrail bracket in position and mark for trimming.
 - 8.5.2 After trimming, test fit elbow along with handrail bracket and spacer.
 - 8.5.3 When fit is confirmed, install end cap on open end of long leg of elbow.
 - 8.5.4 Attach short leg of elbow to handrail tubes with a ring joiner.
 - 8.5.5 Attach handrail bracket and spacer to guard filler section by drilling 5/16" dia. hole through guard filler picket, and then secure using one 5/16"-18 x 3" bolt, nut and washer.
 - 8.5.6 Attach elbow to handrail bracket using one 1/4" x 1" long self drilling square drive screw.
 - 8.5.7 Tighten all fasteners securely.

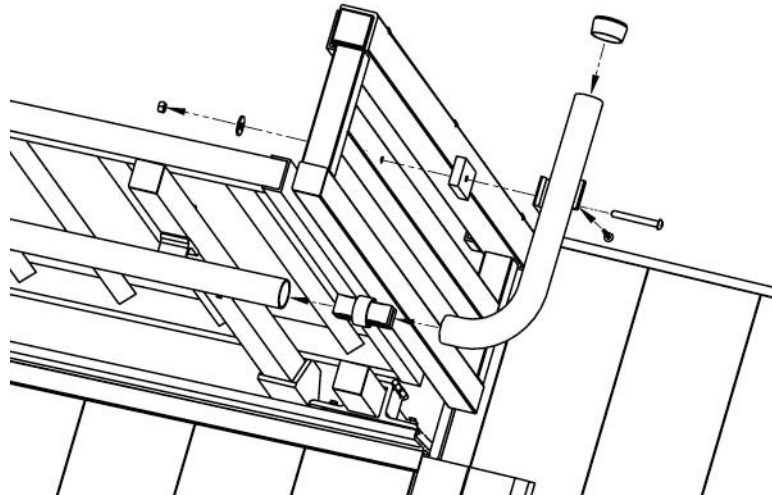

FIG. 42

- 8.6 At a turn-back platform on the inside, turn-back side (FIG. 43):
- 8.6.1 Hold two 90 degree elbows in position and mark for trimming.
 - 8.6.2 After trimming, test fit elbows, handrail brackets and spacers.
 - 8.6.3 Attach long legs of elbows in the middle with a ring joiner, and then attach both elbows to handrail tubes with ring joiners (FIG. 44)
 - 8.6.4 Attach handrail brackets and spacers to guard filler section by drilling 5/16" dia. hole through the filler picket.
 - 8.6.5 Use one 5/16"-18 x 3" bolt, nut and washer per bracket to secure.
 - 8.6.6 Attach elbows to handrail brackets using 1/4" x 1" self drilling square drive screw per bracket.
 - 8.6.7 Tighten all fasteners securely.

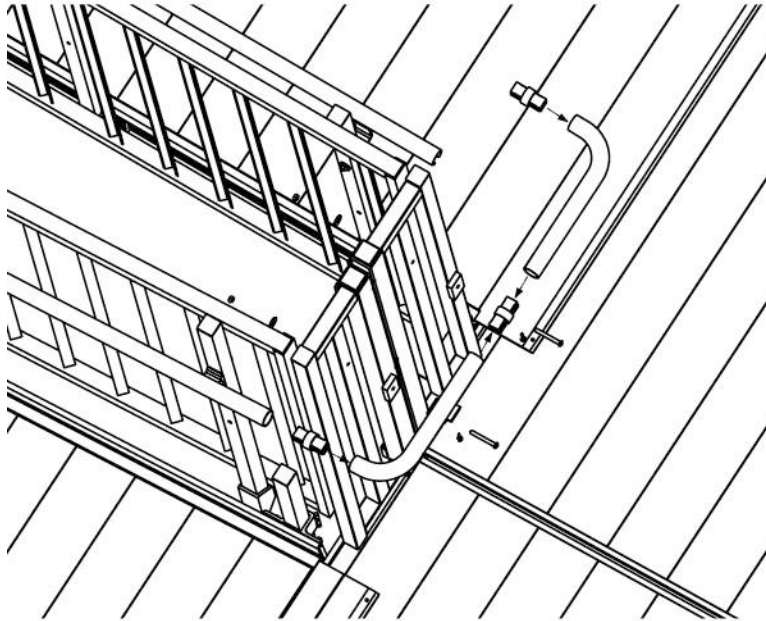

FIG. 43

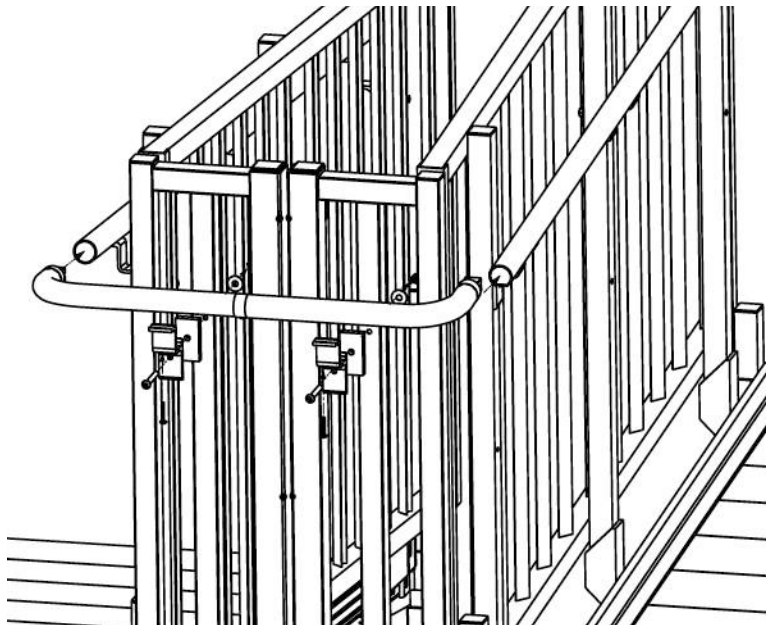

FIG. 44

- 8.7 At an intermediate turn platform on an inside corner (FIG. 45):
- 8.7.1 Hold two 90 degree elbows in position with the adjustable elbow and mark for trimming.
 - 8.7.2 After trimming, test fit elbows, handrail brackets and spacers.
 - 8.7.3 Attach long legs of 90 degree elbows to adjustable elbow with ring joiners then attach both elbows to handrail tubes with ring joiners.
 - 8.7.4 Attach handrail brackets and spacers to guard post using one 5/16" x 1-1/2" self drilling square drive screw per bracket to secure (FIG. 46).
 - 8.7.5 Attach elbows to handrail brackets using one 1/4" x 1" long self drilling square drive screw per bracket then tighten all fasteners securely.

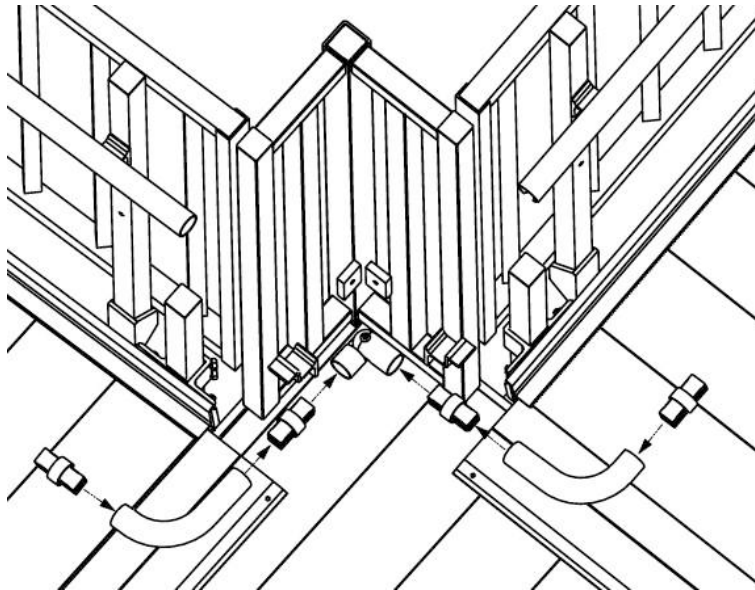

FIG. 45

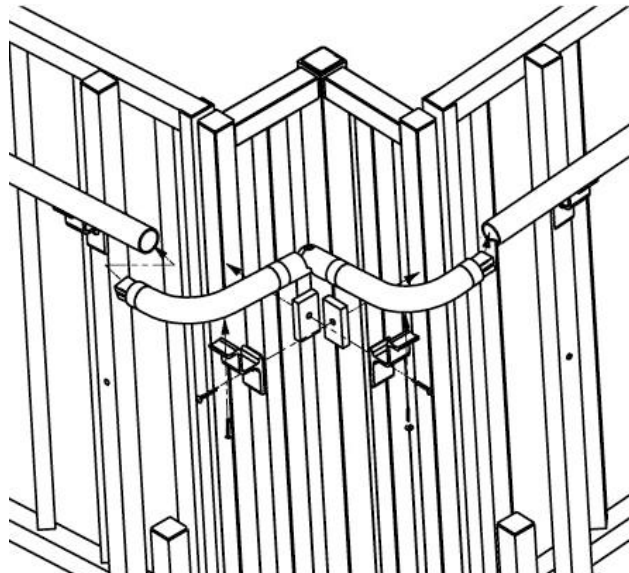

FIG. 46

- 8.8 When child rails are required, the lower (child) handrails and the various returns and connectors are installed in the same manner as the upper (normal) rail using the lower set of holes provided. Refer to instructions in previous steps.
- 8.8.1 The upper (adult) handrail is also installed in the same manner except the upper and lower termination loops are not used. These components will be replaced by either a dual termination loop (FIG. 47).
- 8.8.2 Install connector pieces of dual termination loop into ends of upper and lower handrails.
- 8.8.3 Drill two holes between 0.129" and 0.133" dia. (#30 drill size) through the handrail tube and the connector piece in the underside of the end of each handrail where a dual termination loop is used. Drill one hole approximately 3/4" from the end and the second hole approximately 1-3/4" from the end.
- 8.8.4 Install two 1/8" dia. rivets (provided) in the end of each handrail using holes drilled in previous step.

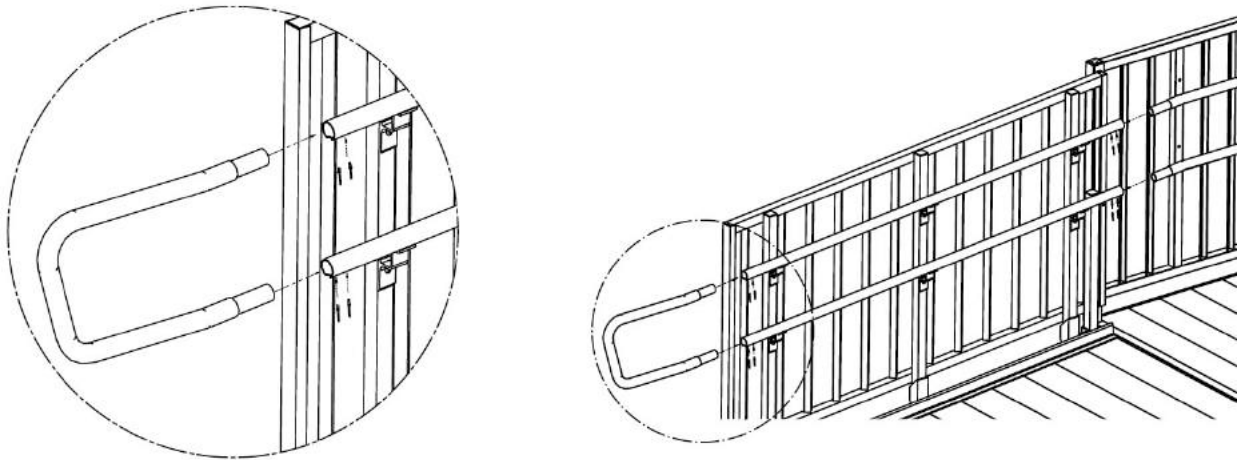

FIG. 47

9. FINAL STEPS:

- 9.1 Once all handrails and components have been positioned and all fasteners tightened, screw transition plates to platforms using two 1/4" x 1" long self drilling square drive screws (FIG. 48).
- 9.2 Ramp and platform feet can be secured to the ground with stakes or concrete anchors (not included) using the holes provided in the feet if needed (FIG. 49).
- 9.3 Ensure that all fasteners are in place and tightened securely.
- 9.4 Walk on the assembled system, check for any slippage of components or undue movement in the system and correct as needed.
- 9.5 Remove all debris and metal chips from the walking surfaces.
- 9.6 Ensure the level of the platforms and the slope of the ramps has not shifted during installation.
- 9.7 Check that all handrails are terminated with loops, returns, or end caps.

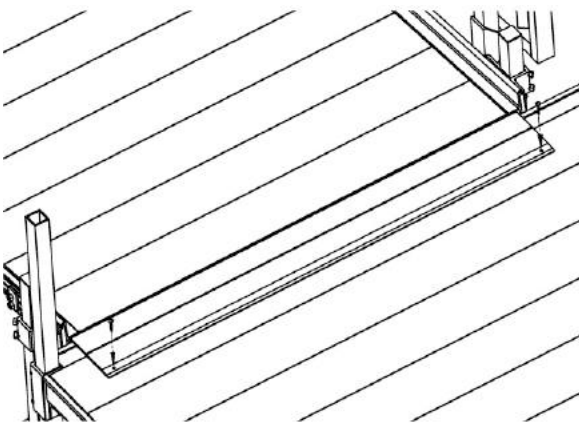
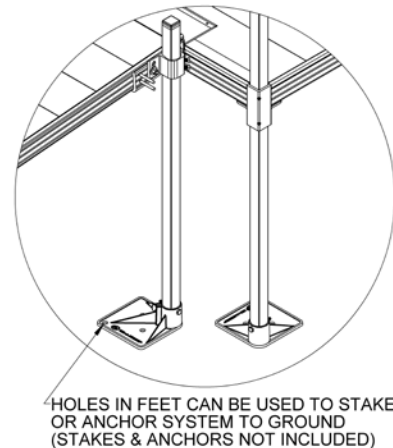
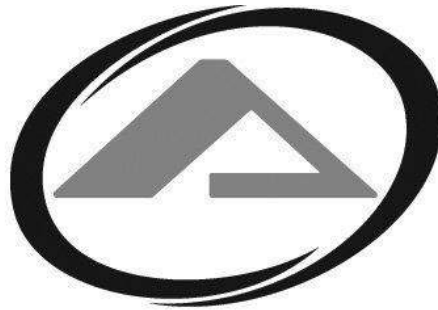

FIG. 48



HOLES IN FEET CAN BE USED TO STAKE OR ANCHOR SYSTEM TO GROUND (STAKES & ANCHORS NOT INCLUDED)

FIG. 49



EZ-ACCESS®

Moving you forward®



© 2013 Homecare Products, Inc. All rights reserved.
All text and images contained in this document are proprietary and may not be shared, modified, distributed, reproduced,
or reused without the express written permission of EZ-ACCESS®, a division of Homecare Products, Inc.

10257 REV 03-31-15