

# Rifton Activity Chair

R820, R830, R840, R850, R860 & R870

Product Manual



Standard Base



Hi/lo Base



# Contents

---

Important information	4
Safety messages	5
Recommended use	6
User and item dimensions	6-8
Check your order	9
Basic components	
Backrest and pads	9
Seatbelt	10
Arm supports	11-12
Seat depth	13
Tilt-in-space	13
Spring options	14-16
Seat quick-connect	17-18
Standard base	
Adjustable legs	19
Seat height	19
Footboard	19
Hi/lo base	
Seat height	20
Caster brakes and swivel lock	21
Footboard	22

# Contents continued. . .

---

## Accessories

---

Headrests	23
Whitmyer adapter plate	24
Lateral supports	25
Chest strap	26
Butterfly harnesses	27
Thigh belt	28
Pelvic harness	29
Hip guides	30
Abductor	31
Adductors	31
Leg prompts and ankle straps	32
Sandals and wedges	33
Lumbar and seat support kit	34
Backrest filler pad	34
Tray	35
Handhold	35
Push handles	36
Footboard lift	36
Mini kit	37
Maintenance, cleaning and warranty	38
Materials and user modifications	39

---

## IMPORTANT

Please save this product manual for future reference. Additional copies are available

## Key for users

Use this key to determine which sections of this product manual apply to you.

 **Technical Users** For professionals who order and set up Rifton products.

 **Home Users** For care-givers who use Rifton products on a regular basis.

 **Maintenance Personnel** For anyone who is responsible for service or re-ordering of Rifton products and parts.

## **WARNING**



- Thoroughly read and understand the information in this product manual before attempting to use this product. If the procedures and instructions in this product manual are not followed, serious injury or death could occur.
- A qualified professional must assess the appropriateness and safety of all equipment for each user.
- This product is intended for use by clients of unreliable judgment. Adult supervision is required at all times.
- To prevent falls and injuries:
  - Do not use this product on rough and uneven terrain, around swimming pools, or near stairways.
  - Ensure the appropriate use of straps and supports at all times. Straps and supports are provided for the safety of the user and must be carefully adjusted for comfort and security.
  - Tighten all adjustment knobs before use and immediately after making any adjustments.
- To prevent pinching or crushing:
  - Keep clients away from under the seat of the chair.
  - Keep hands above the seat when the spring option is in use.
- To prevent falls, strangulation, head entrapment or other injuries, always use seatbelt or pelvic harness when the tray, chest straps, thigh belt, mini trunk support, or butterfly harness are in use.
- Do not use this product for clients outside the height and weight limits specified in this manual.
- To prevent structural failure, which may result in serious injury or death:
  - Inspect this product and accessories regularly for loose or missing screws, metal fatigue, cracks, broken welds, missing attachments, general instability or other signs of excessive wear.
  - Immediately remove this product from use when any condition develops that might make operation unsafe.
  - Do not use Rifton components or products for any purpose other than their intended use.

# Recommended use

The Rifton Activity Chair is a Class 1 medical device. It is intended to provide comfortable seating with adjustable support for people with disabilities in the classroom or at home. The chair allows for growth, can be used by multiple users and is available with various accessories that are easily removable as the client gains independence.

## Small user and item dimensions

User dimensions – inches (cm)	R820 Standard base	R830 Hi/lo base
Height	32–48 (81-122)	32–48 (81-122)
with mini kit	28–38 (71-97)	28–38 (71-97)



**Key user dimension: height**  
The user's overall height is a general guide to help you select the appropriate chair. Choose the model that allows for growth.

**Important:** Make sure that seat width, depth and height are adequate for each individual user, and that the user's weight does not exceed the maximum weight recommended.

Item dimensions – inches (cm)	R820 small Standard base	R830 small Hi/lo base
Frame width	short legs: 21 (53)	25 (63)
	long legs: 23 (58)	
Seat height above floor	short legs w/ wheels: 22½ (57)	10–25 (25-64)
	long legs w/ wheels: 23½ (60)	
	short legs: 9½–12½ (24-32)	
	long legs: 18½–21½ (47-55)	
	short legs w/ wheels: 13½–16½ (34-42)	
	long legs w/ wheels: 18½–21½ (47-55)	
Seat angle (tilt-in-space) - degrees	15° forward, 15° back	15° forward, 25° back
Backrest angle - degrees	5° forward, 20° back	5° forward, 20° back
Seat height above footboard with mini kit	9–12 (23-30)	9–12 (23–30)
	6–9 (15-23)	
Seat width with hip guides (without hip guides)	7–9 (18-23)	7–9 (18–23)
	12 (30)	
Seat depth with mini kit	8–12 (20-30)	8–12 (20–30)
	7–11 (18-28)	
Armrest height above seat	5–7½ (13-19)	5–7½ (13–19)
Trunk support width	5½–11½ (14-29)	5½–11½ (14–29)
Backrest height	12½–15½ (32-39)	12½–15½
Headrest height above seat	14½–21 (37–53)	14½–21 (37–53)
Max. working load – lbs. (kg)	75 (34)	75 (34)

# Medium user and item dimensions

User dimensions – inches (cm)	R840 Standard base	R850 Hi/lo base
Height	40–56 (102–142)	40–56 (102–142)



**Key user dimension: height**  
 The user's overall height is a general guide to help you select the appropriate chair. Choose the model that allows for growth.

**Important:** Make sure that seat width, depth and height are adequate for each individual user, and that the user's weight does not exceed the maximum weight recommended.

Item dimensions – inches (cm)	R840 medium Standard base	R850 medium Hi/lo base
Frame width	short legs: 23¼ (59)	27½ (70)
	long legs: 24½ (62)	
	short legs w/ wheels: 24½ (62)	
	long legs w/ wheels: 25½ (65)	
Seat height above floor	short legs: 12½–16½ (32–42)	12–23 (30–58)
	long legs: 19–23 (48–58)	
	short legs w/ wheels: 16–20 (41–51)	
	long legs w/ wheels: 19–23 (48–58)	
Seat angle (tilt-in-space) - degrees	15° forward, 15° back	15° forward, 25° back
Backrest angle - degrees	5° forward, 20° back	5° forward, 20° back
Seat height above footboard	12–16½ (30–41)	12–16½ (30–41)
with footboard lift	8–12½	8–12½
Seat width with hip guides (without hip guides)	8½–11½ (22–29)	8½–11½ (22–29)
	14 (36)	14 (36)
Seat depth	11–16 (28–41)	11–16 (28–41)
Armrest height above seat	7–10½ (18–27)	7–10½ (18–27)
Trunk support width	6½–12 (17–30)	6½–12 (17–30)
Backrest height	15½–19 (39–48)	15½–19 (39–48)
Headrest height above seat	17½–24½ (44–62)	17½–24½ (44–62)
Max. working load – lbs. (kg)	150 (68)	150 (68)

# Large user and item dimensions

User dimensions – inches (cm)	R860 Standard base	R870 Hi/lo base
Height	50–74 (127–188)	50–74 (127–188)



**Key user dimension: height**  
 The user's overall height is a general guide to help you select the appropriate chair. Choose the model that allows for growth.

**Important:** Make sure that seat width, depth and height are adequate for each individual user, and that the user's weight does not exceed the maximum weight recommended.

Item dimensions – inches (cm)	R860 large Standard base	R870 large Hi/lo base
Frame width	short legs: 26¼ (66)	29¾ (75)
	long legs: 26¼ (66)	
	short legs w/ wheels: 27¾ (71)	
	long legs w/ wheels: 27¾ (71)	
Seat height above floor	short legs: 16½–20½ (42–52)	16–24 (41–61)
	long legs: 20–24 (51–61)	
	short legs w/ wheels: 16½–20½ (42–52)	
	long legs w/ wheels: 20–24 (51–61)	
Seat angle (tilt-in-space) - degrees	15° forward, 15° back	15° forward, 25° back
Backrest angle - degrees	5° forward, 20° back	5° forward, 20° back
Seat height above footboard	15–20 (38–51)	15–20 (38–51)
with footboard lift	11–16	11–16
Seat width with hip guides (without hip guides)	11–14 (28–36)	11–14 (28–36)
	17 (43)	17 (43)
Seat depth	15–20 (38–51)	15–20 (38–51)
Armrest height above seat	7–10½ (18–27)	7–10½ (18–27)
Trunk support width	9½–14 (24–36)	9½–14 (24–36)
Backrest height	19–24 (48–61)	19–24 (48–61)
Headrest height above seat	19½–29½ (50–75)	19½–29½ (50–75)
Max. working load – lbs. (kg)	225 (102)	225 (102)



# Check your order

Your Rifton chair has been shipped according to your specifications. It will require some tool-free assembly. Follow these instructions to insure that your chair is put together and used correctly. This product manual is comprehensive and may discuss features not included in your chair.

**If your shipment is incomplete or in any way damaged on arrival, please call Customer Service.**

# Basic components

*A Quick Reference Guide for your chair is located behind the backrest pad.*

**Tip:** Every white lever or button indicates a point of adjustment.

## Backrest

**Backrest angle and height adjust with one-hand levers.**

To adjust backrest angle, squeeze white backrest angle lever and move backrest forward or backward to desired angle, then release lever (see Figure 9a).

To adjust backrest height, press backrest height lever and raise or lower backrest to desired position. Release lever and click backrest into position (see Figure 9a).

## Pads

**Backrest and seat pads snap into position.**

Backrest pad has a Rifton tag (see Figure 9b) and is snapped onto studs (A) located behind top and bottom edge of backrest (see Figure 9c).

Seat pad has no tag and is snapped onto studs (B) located under front and back edge of seat (see Figure 9c).

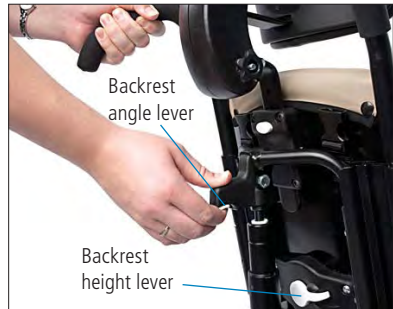

Figure 9a



Figure 9b

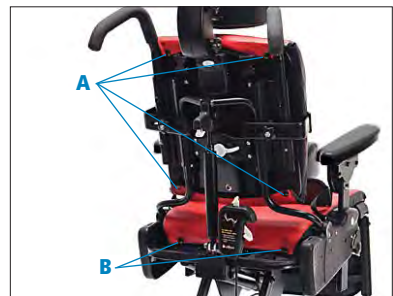

Figure 9c

## Seatbelt

**⚠ WARNING** To prevent falls, strangulation, head entrapment or other injuries, always use seatbelt or pelvic harness when the tray, chest straps, thigh belt, mini trunk support, or butterfly harness are in use.

To attach seatbelt (see Figure 10a), use a pen to press small white button (C) just below one of the slots (B) at the side of the seat. While keeping button depressed, insert the L-shaped metal clip (A) on the seatbelt strap into the slot with back of L-shape towards front of seat. Press clip firmly into slot and release button, making sure clip locks and holds when pulled. Repeat on other side of seat.

To remove the seatbelt, use a pen to press small white button (C) just below clip slot on side of seat, and pull belt up to disengage clip. Repeat on other side of seat.

**Tip:** Seatbelt can be clipped into either set of small slots at sides of chair (B).

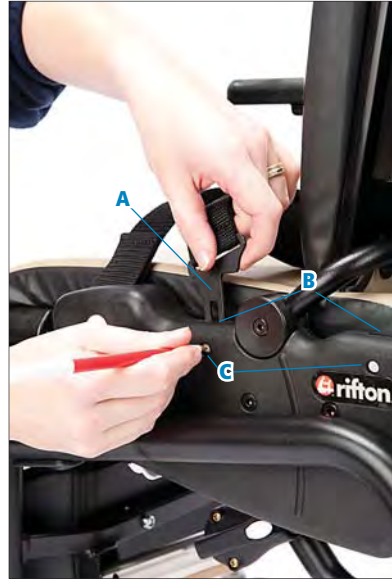

Figure 10a

## Arm supports

**A pair of either armrests or forearm prompts were purchased with the chair.**

Insert arm supports into large slots at either side of seat.

Both types of arm supports can be removed for side transfers.

To insert arm support and adjust its height, press white button (A) just below arm support slot at side of seat. Insert arm support, move it up or down to required height, release button and make sure it audibly locks into place (see Figure 11a).

To remove arm support, press white button below arm support slot at side of seat and pull arm support up.

**Armrests can be set at a wide range of angles.**

**Tip:** Cut-outs on armrests should be toward back of chair.

To set angle of armrest, lift white tab (B) below outer edge of armrest (see Figure 11a) and rotate armrest to desired angle. Release tab and make sure armrest audibly locks into place.



Figure 11a (Armrests)

## Arm supports continued. . .

**Forearm prompts adjust fully to facilitate trunk and head control while sitting.**

Forearm prompts are attached using a clamp and post system (see Figure 12b). The clamp attaches with a knob (F) to any position on the bar, and can be attached on the inside or outside of the bar (G) (see Figure 12a).

The post fits into the clamp and provides up/down and rotational adjustment.

Arm prompt can be attached to the post at several angles by sliding or rotating to achieve the best position for the user. Loosen knob (A) to make adjustments (see Figure 12b).

Adjust the forearm prompts to the best position for a user's comfort and function. Slide or rotate the handgrip (see Figure 12b), by loosening, then tightening knob (C). Adjust straps (D and E) (see Figure 12a) and secure with hook and loop fasteners (hooks away from the user's arm).



Figure 12a ( Forearm prompts)

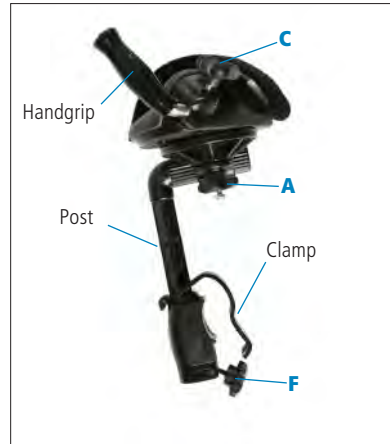

Figure 12b

## Seat depth

To adjust seat depth, pull white handle located below seat (see Figure 13a). Move seat forward or back to desired position and release handle. Make sure seat audibly locks into place.



Figure 13a

## Tilt-in-space

**⚠️ WARNING** To prevent pinching or crushing, keep hands and limbs away from moving parts when adjusting chair.

Tilt-in-space positions entire seat and backrest into a rest position from active sitting and vice versa.

To adjust tilt-in-space angle, place one hand on push handle or top of backrest and with other hand squeeze tilt lever and safety lock (see Figure 13b). Push backrest forward or pull backward until desired angle is reached, then release levers to lock seat and backrest.

Use angle indicator (see Figure 13c) on side of chair for consistent positioning.



Figure 13b



Figure 13c

## Back and seat springs

Spring option allows for user-initiated movement and allows chair to “bounce.”

The Standard base with spring option has spring in backrest and seat (see Figure 14c).

The Hi/lo base with spring option has spring in backrest only.

There are two locked (non-dynamic) positions on the backrest gas spring. When locked, each position gives 15° of angle adjustment using the backrest angle lever. The seat spring also has two locked, (non-dynamic) positions, each giving 15° of adjustment using the tilt-in-space lever (see Figures 14a and 14b).

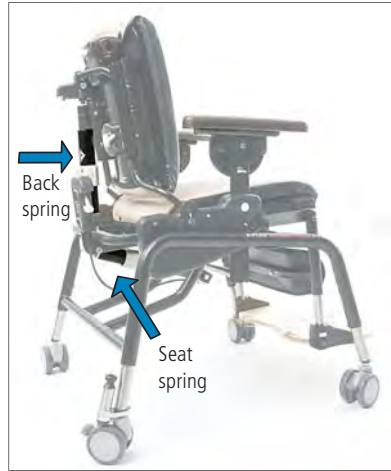

Figure 14a

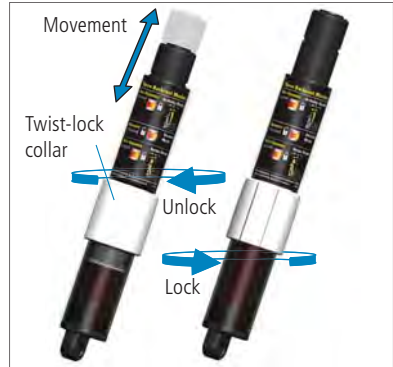

Figure 14b



Figure 14c

**Activity mode (-10° to +5°):**

To lock the backrest in the upright position, turn the twist-lock collar to the right until it locks (see Figure 15b). With the angle lever adjust the backrest angle forward or back 15° (see Figure 15c)

**Tip:** When locking the backrest spring option, it may be necessary to move backrest forward or back to enable twist-lock collar to slip into position.

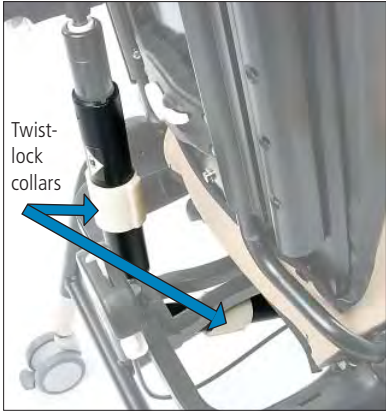

Figure 15a



Figure 15b



Figure 15c (adjusting back angle)

**Relax mode (-20° to -5°):**

To position and lock the backrest for reclined resting, unlock the white twist-lock collar (see Figure 16a). Push down and back on the top of the backrest (not on the headrest) until the groove around the movable gas cylinder almost retracts into the outside cylinder. While still holding the backrest down, turn the white twist-lock collar down, turn the white twist-lock collar to the right until it locks (see Figure 16b). Adjust the angle of the backrest forward or back 15° using the angle lever (see Figure 16c).

This function is easier to perform with the client in the chair.

**Extra seat recline (on standard base only):**

If the seat has a gas spring (located under the seat) it will also have two locked (non-dynamic) positions allowing an extra 15° of recline from the tilt-in-space. To unlock the seat spring, rotate the twist-lock collar under the seat counter-clockwise. Turn it clock-wise to lock it and then use the tilt-in-space lever to make final adjustments.



Figure 16a

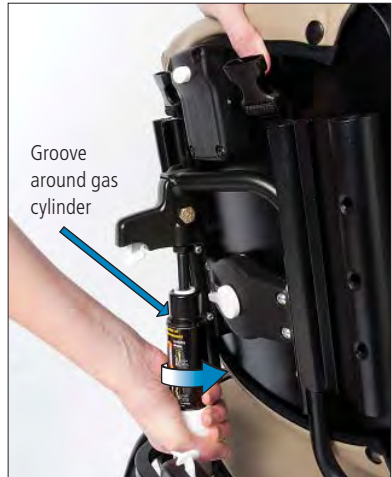

Figure 16b



Figure 16c



## Seat quick-connect

The Rifton Activity Chair seat and backrest unit can be detached from its base and re-attached to any other Rifton Activity Chair base of the same size. Thus, a Rifton Activity Chair standard base can be converted to a Hi/lo base and vice versa, by ordering the base required.

### Detaching seat and backrest:

First disconnect footboard angle adjuster, if it has a footboard (see Figure 17a). To do this, reach beneath seat, press tube latch and pull footboard up and away from seat until tubing drops out of housing (see Figure 17a). Lock casters, if present and remove arm supports.

Find two white levers (A and B) located beneath the chair seat (see Figure 17b). Place one hand under front edge of seat and lift it up. At the same time, with the other hand, pull lever (A) towards front of chair. Still lifting front edge of seat, pull second lever (B) towards front of chair to disengage seat from crossbar (C).

Once front of seat is disengaged (see Figure 17c), pull entire seat and backrest towards front of chair until seat hoop (D) disengages from metal prongs (E).

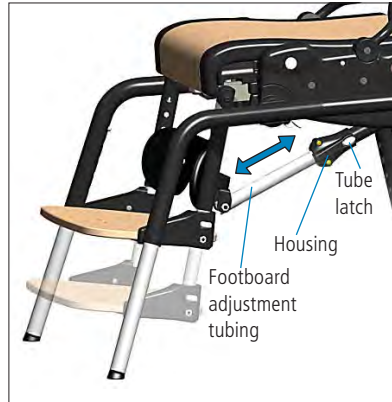

Figure 17a

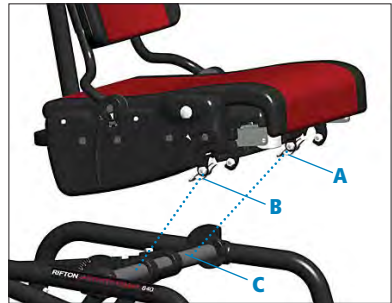

Figure 17b



Figure 17c

## Attaching seat and backrest

**⚠ WARNING** To prevent falls and injury, ensure that the seat is firmly attached at the front and back before use.

If the seat is being installed on a Hi/lo base, raise the base to its full height first.

To attach, slide seat hoop (D) under prongs (E) on base, centering backrest column between prongs (see Figure 18a). Then lower seat onto crossbar (C) (see Figure 18b), pushing firmly down on front edge until it snaps into place.

Reconnect footboard adjustment tubing to its housing by holding housing and tubing in a straight line to one another. Press tube latch, insert tubing into housing and make sure it audibly locks into place at desired setting (see Figure 18c).

**Tip:** Detaching seat from base and re-attaching it to another base works best with two people, one on either side of chair.

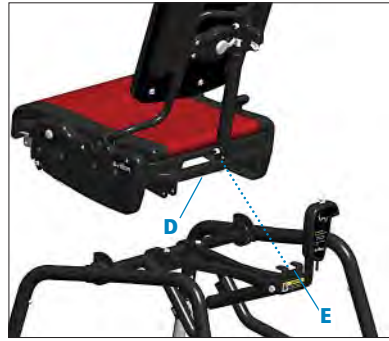

Figure 18a

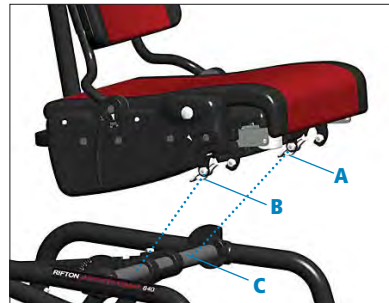

Figure 18b

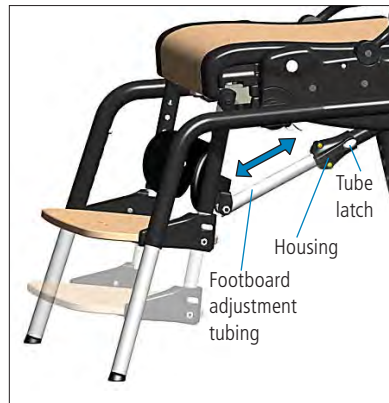

Figure 18c

# Standard base

## Adjustable legs

**WARNING** To prevent falls and injury:

- Adjust all legs on a chair to the same length.
- Always use four legs of a set together on one chair; do not connect legs of varying lengths or varying features to the same chair.

**CAUTION** To permit steering and prevent injury, ensure that the caster with the swivel lock function is inserted into the right rear leg of the base frame (see Figure 19b).

For more information on caster function, see page 21.

A set of four long legs, or four short legs, or four long legs with casters, or four short legs with casters have already been purchased with the standard base. Additional sets of legs may be purchased as an accessory.

To connect leg to chair, press snap button and insert leg into housing. Release snap button and make sure leg clicks into place (see Figure 19a). To disconnect leg from chair, press snap button and pull leg out of housing.

## Seat height

The selection of long or short legs, with or without casters will impact seat height. To adjust seat height, press snap button on each adjustable leg, push or pull leg to desired setting, release snap button and make sure it audibly locks into place (see Figure 19a).

## Footboard

Footboard is an accessory with standard base. For information on footboard and its adjustments, see page 22.

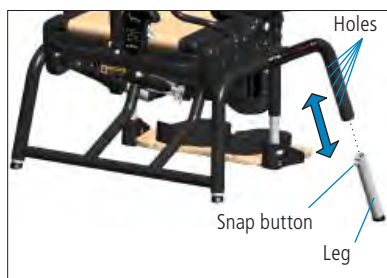

Figure 19a



Figure 19b

## Hi/lo base

**▲ WARNING** To prevent pinching or crushing, keep hands and limbs away from moving parts when adjusting chair.

### Large & medium chair seat height (R850 & R870)

To adjust seat height, use foot pedal located at rear of chair. To raise seat, repeatedly pump foot pedal until desired height is achieved. To lower seat, lift the red safety lock and foot pedal up until the seat descends to desired height (see Figure 20a).

### Small chair seat height (R830)

To adjust seat height, use handle behind backrest. Squeeze and hold both triggers while pulling up or pushing down (see Figure 20b).



Figure 20a

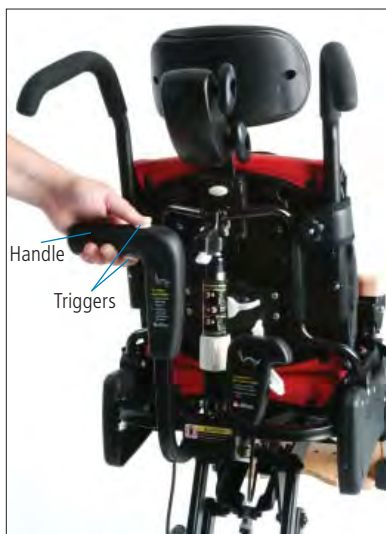

Figure 20b

## Caster brakes

**⚠ WARNING** To prevent falls and injury, apply caster brakes prior to transferring clients into or out of the chair.

To apply brake, step down on pedal (A) protruding from caster wheel (see Figure 21a). To release brake, lift pedal up.

## Swivel lock

**Swivel lock can be used to keep chair from drifting sideways when it is being pushed.**

To apply swivel lock, position caster directly beneath swivel lock post and push handle down with foot. Swivel lock post will drop into caster groove and stop just above brake pedal (see Figure 21b).

To release swivel lock, pull up on white knob until snap button audibly locks into place above metal collar.

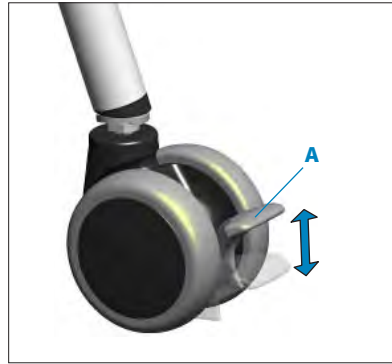

Figure 21a

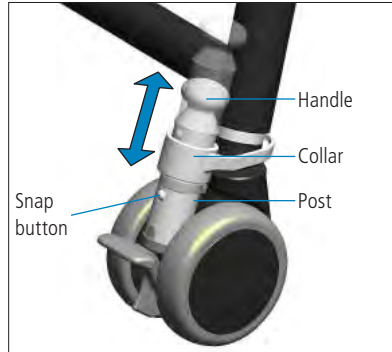

Figure 21b

# Footboard

**⚠ WARNING**

To prevent falls and injury, ensure footboard push buttons have engaged before allowing client to step onto footboard.

The footboard supports the user's feet, when the seat is too high for feet to touch the floor. It also serves as a base for ankle straps, sandals, and wedges. The footboard supports the weight of the user during transfers, or it can be swung out of the way beneath the seat.

To set angle of footboard (see Figure 22a), reach beneath seat and press white tube latch on footboard angle adjuster. With other hand push or pull footboard to desired setting, then release latch and make sure it audibly locks into place (see Figure 22b).

To adjust footboard height, simultaneously press the white footboard buttons located on both sides of footboard. Slide footboard up or down evenly on both sides to desired setting. Make sure footboard audibly locks into place (see Figure 22c).

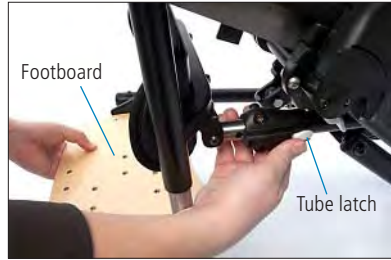

Figure 22a

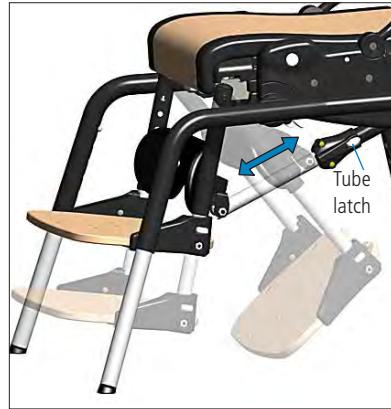

Figure 22b



Figure 22c

# Accessories

## Headrests

Headrests with a flat, contoured or adjustable winged headpiece can be purchased (see Figure 23a).

The adjustable winged headpiece allows each wing to adjust independently from almost flat to perpendicular, providing more depth and width possibilities.

To attach and adjust headrest height, press white button (A), insert metal headrest bar and raise or lower it to desired setting. Release button and make sure headrest audibly locks into place (see Figure 23b).

To adjust depth and angle of headrest, loosen both black knobs (see Figure 23b). Move headrest to desired position and tighten both knobs securely.



Figure 23a

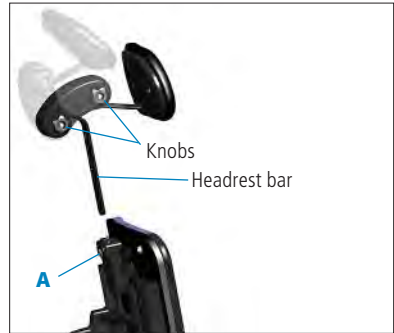

Figure 23b

## Whitmyer adaptor plate

**⚠ WARNING** This product must always be assembled and serviced by a responsible adult.

Whitmyer headrests can be installed on all Rifton Activity Chairs. Rifton's adaptor plate gives you the option to use a Whitmyer M2100 headrest mounting bracket and Whitmyer Onyx Headrest Support System (see Figure 24b).

To adapt to the Whitmyer Onyx Headrest Support System, purchase the Whitmyer M2100 mounting bracket from an authorized Whitmyer dealer.

Using the 5/32" Allen wrench provided, remove the four screws holding the Rifton headrest bracket. Place the adapter plate over the upper two holes. Securely fasten the Whitmyer M2100 mounting bracket into the top two holes (see Figure 24a) using the Rifton adapter plate between the bracket and the backrest. The two 1/4" screws that come with the Whitmyer mounting bracket require a 3/16" Allen wrench.

**NOTICE** The customer assumes full responsibility that this field modification is correctly and safely completed. Rifton does not recommend nor guarantee that the Whitmyer headrest will satisfy the needs of the customer. Rifton is not responsible for the installation or safe use of Whitmyer products.

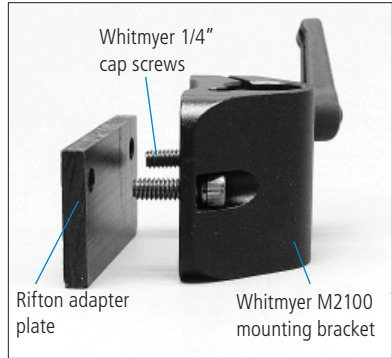

Figure 24a



Figure 24b



## Lateral supports

Lateral supports provide comfortable lateral support for the user and are fully adjustable in height, width and angle. They can be purchased either with or without chest strap attached.

To attach and/or adjust lateral support (A), loosen black knob (B) and insert the key (C) into extrusion (D) behind backrest (see Figure 25a). Adjust height, angle and width of laterals to fit client by sliding lateral support up and down the extrusion sliding bracket (E), and by rotating the bracket around the knob. When desired adjustment is reached, tighten knobs firmly (see Figure 25b).

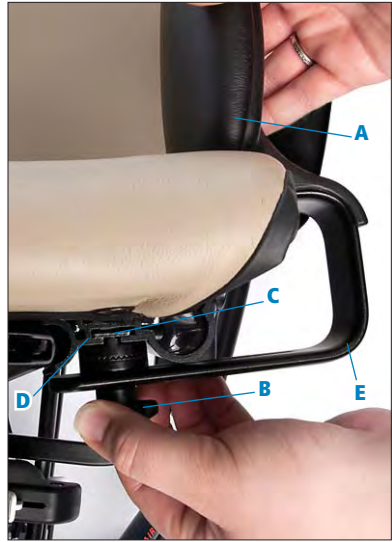

Figure 25a (Chair top view)

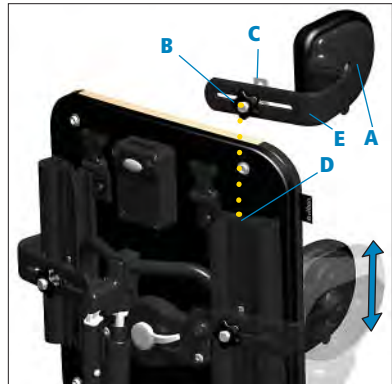

Figure 25b

## Chest strap

**⚠ WARNING** To prevent falls, strangulation, head entrapment or other injuries:

- Always use seatbelt or pelvic harness when the tray, chest straps, thigh belt, mini trunk support, or butterfly harness are in use.
- Ensure correct adjustment and positioning of the chest strap at each use.

The chest strap provides anterior support. Two types of chest straps can be purchased: one for use with lateral supports, the other for use on its own.

The stand-alone chest strap may be used with lateral supports, but will not be in line with lateral supports like the compatible chest strap is.

To attach chest strap to lateral supports, thread loop at either end of chest strap over the knob and key assembly of lateral supports (see Figure 26a), making sure buckle faces away from the client.

Loops can be threaded either with chest strap encompassing lateral supports, or with straps on the inside of lateral supports (see Figure 26a).

The stand-alone chest strap, is wider than the chest strap for use with lateral supports (see Figure 26b). To attach, loosen black knobs at both ends of strap and insert the keys into the extrusions behind backrest. Slide knobs up and down until desired height is achieved, then tighten knobs firmly (see Figure 26c).



Figure 26a



Figure 26b



Figure 26c

## Butterfly harness

**⚠️ WARNING** To prevent falls, strangulation, head entrapment or other injuries:

- Always use seatbelt or pelvic harness when the tray, chest straps, thigh belt, mini trunk support, or butterfly harness are in use.
- Ensure correct adjustment and positioning of the butterfly harness at each use.
- Always use lateral supports in conjunction with the butterfly harness if necessary to ensure clients do not slump sideways.

The butterfly harness provides anterior support while allowing maximum freedom of movement.

With back of L-shape towards front of seat, attach butterfly harness by inserting L-shaped metal clip (A) at the ends of lower harness straps into slots (B) on both sides of seat. Use pen to insert clips, as shown on page 10. Press clips firmly into slot making sure clips hold when pulled (see Figure 27a). Then clip top buckles (E) together behind top of backrest (F) (see Figure 27b).

The butterfly harness can be clipped into either set of small slots at sides of chair seat. Use other set for seatbelt or pelvic harness.

To remove butterfly harness, use pen to press small white button (C) and pull harness up to disengage clip. Repeat on other side of seat (see Figure 27a).

To completely free the butterfly harness, unclip all four buckles (D and E) (see Figures 27a and 27b). Transfer client into Activity Chair, then place harness pad on user's chest. Secure all four buckles and adjust straps as necessary.



Figure 27a



Figure 27b

## Slim-cut butterfly harness

The slim-cut butterfly harness is slim across the chest, making it more comfortable for female clients. It performs the same positioning function as the regular butterfly harness.

To attach slim-cut butterfly harness follow the regular butterfly harness instructions.

## Thigh belt



**WARNING** To prevent falls, strangulation, head entrapment or other injuries, always use seatbelt or pelvic harness when the tray, chest straps, thigh belt, mini trunk support, or butterfly harness are in use.

A thigh belt can provide additional support and security for user's thighs and helps adduct user's knees.

To attach thigh belt, unsnap and lift up front of seat pad. Hold metal slide over recessed side of H-slot with belt extending over closest edge and plastic buckle down (see Figure 28a). With other hand, pinch sides of belt together about 1.5" away from metal slide. Shove pinched belt section through cross bar of H-slot and push more through until belt is flat, then pull up. Metal slide should be on top with belt looping below seat. Repeat with other end of belt. Replace seat pad.

To remove thigh belt, first remove seat pad. Grasp thigh belt strap directly above slot from which it protrudes, and pinch strap edges into cross-bar of H-slot. Push down on strap to loosen metal slide from recess in which it is seated. Grasp metal slide with other hand and pull strap free. Repeat on other side, then replace seat pad.

To adjust thigh belt, pull adjuster straps threaded through either side of center buckle (see Figure 28b).

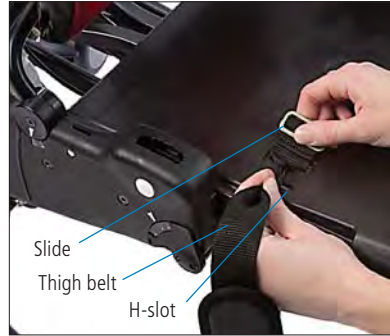

Figure 28a



Figure 28b

## Pelvic harness

**⚠ WARNING** To prevent falls, strangulation, head entrapment or other injuries, always use seatbelt or pelvic harness when the tray, chest straps, thigh belt, mini trunk support, or butterfly harness are in use.

The pelvic harness may be used in place of a seatbelt as the primary means of securing a user in the chair. This alternative to the more typical seatbelt gives a stable base for developing sitting postural control. The pelvic harness firmly positions the user's pelvis by securing hips and upper thighs without placing pressure on the abdomen.

To attach pelvic harness, place it on seat with wide ends towards back of seat and strap attachment points down. Insert L-shaped metal clips, attached by short straps to back corners of harness, into slots at either side of seat. Use pen to insert clips, as shown on page 10. Press clip firmly into slot with back of L-shape towards front of seat, making sure it audibly locks into place and holds when pulled (see Figure 29a).

Lay the harness pad flat on the seat as shown (see Figure 29b). Seat the client in the chair. Pull each end of the pad between the legs and over the near leg (e.g., left pad end over the left leg) (see Figure 29c). Secure the buckles. Tighten the straps as necessary.

To remove pelvic harness, use pen to press small white button just below clip slot on side of seat and pull harness up to disengage clip. Repeat on other side of seat.

The pelvic harness can be clipped into either set of small slots at sides of the chair. Be sure to consider seat depth required for user and assess that the slot selected for attachment will allow appropriate use of pelvic harness.



Figure 29a

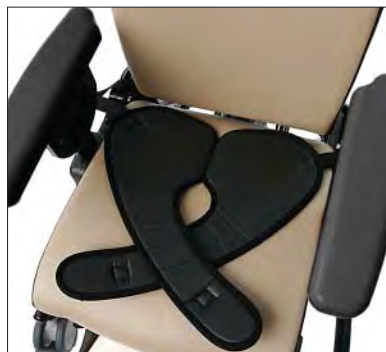

Figure 29b



Figure 29c

## Hip guides

**Hip guides give additional lateral support to the user's hips and can be adjusted independently for best fit.**

**Hip guides are clipped to arm supports, either armrests or forearm prompts, and can be removed along with arm supports for transfers.**

To attach the left hip guide: Remove the left arm support. Place the left hip guide over the arm support slot with the white button for lateral adjustments on the outside of the chair facing the backrest (see Figure 30a). Slide the arm support through the hip guide and into the chair slot.

**Tip:** Match the raised molded armrest outline on the hip guide with the armrest shape (see Figure 30b).

Repeat in reverse to attach right hip guide.

To adjust width between left and right hip guides, press white button and move hip guide pad in and out, making sure it audibly locks into place when desired setting is reached.

**Tip:** Small hip guides can be used with the mini kit.



Figure 30a



Figure 30b

## Abductor

**The abductor keeps the user's knees comfortably apart.**

Before attaching abductor, remove leg prompts, if present.

To attach abductor, insert abductor post into slot centered directly beneath front of seat. Reach below slot and press white abductor button to insert abductor post into slot (see Figure 31a).

To adjust depth of abductor to seat, press white abductor button and pull abductor to desired setting then release button making sure abductor audibly locks into place.

## Adductors

**Adductors limit lateral movement of user's knees and provide a comfortable lateral boundary.**

To attach adductors, press adductor button and insert metal posts into slots located in front corners on the sides of the seat, with adductor pads towards seat. Release button and make sure adductors snap into place.

To remove adductors, press the white adductor buttons located below front corners of seat and pull adductors out (see Figure 31b).



Figure 31a



Figure 31b

## Leg prompt

**Leg prompt can be used in place of an abductor providing both abduction and adduction.**

Before attaching leg prompt, remove abductor, if present.

To attach leg prompt, insert leg prompt post (A) into slot (B) centered beneath front of seat. Reach below slot and press leg prompt button (C), to insert it (see Figure 32a).

To adjust depth of leg prompt to seat, press leg prompt button (C). Pull or push leg prompt until desired setting is achieved. Release button and make sure leg prompt audibly locks into place.

To adjust width of leg prompt, press white width buttons (D) located on plastic housing behind leg prompt straps. To move leg prompts closer or farther apart, release buttons when desired setting is achieved, making sure prompt audibly locks into place (see Figure 32a).

Secure user's legs in place with leg prompt straps (see Figure 32b).

## Ankle straps

**Ankle straps secure the user's feet while providing a bounded range of movement (see Figure 32c).**

To attach the ankle straps, insert the ends of the straps into the T-slots at the back of the footboard. Pull ankle straps firmly up to secure the clips beneath the T-slots (see Figure 32d). Adjust straps to fit user's needs.

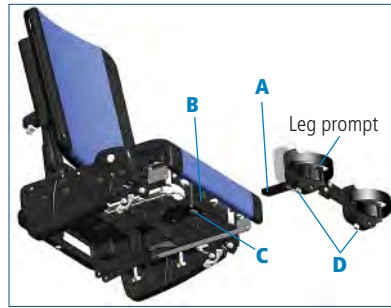

Figure 32a



Figure 32b



Figure 32c



Figure 32d



## Sandals and Wedges

Sandals provide positive positioning of the user's feet and require the footboard. Adding wedges beneath sandals allows for custom fit of sandal height and tilt. Sandal bases come as a left and right pair.

To attach, position sandal base on footboard above one of the pairs of screw threads embedded in footboard. Use black knobs to secure sandal base to footboard. Begin by tightening knobs only halfway, slide sandal base to desired position, then tighten knobs firmly (see Figure 33a).

Latch each sandal onto sandal bases using white lever (see Figure 33c)

To attach wedge, pull back white lever at side of sandal to remove it from its base. Place wedge on sandal base and push bottom lever back, locking wedge onto base. Add wedges as needed. Place sandal on top of stack and lock it by pushing corresponding white lever (see Figures 33b and 33c). Make sure sandals and wedges are firmly locked together before use.

Wedges may be used either way around when stacked.

Secure the user's feet with sandal straps.

**Tip:** Sandals cannot be used together with ankle straps.

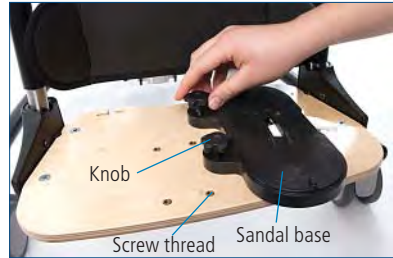

Figure 33a

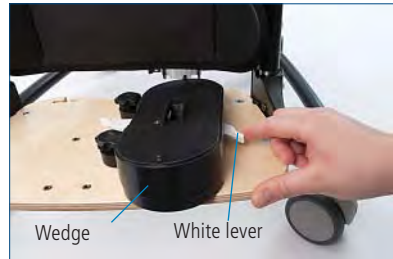

Figure 33b

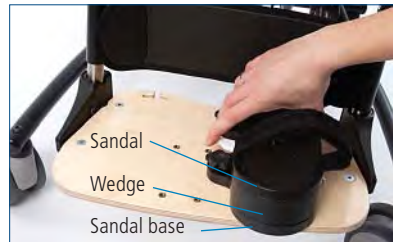

Figure 33c

## Lumbar and seat support kit

The lumbar and seat support kit can be custom-cut and fitted to give extra postural support.

The lumbar support secures behind the backrest pad for additional low back support. The seat support secures beneath the seat pad to help prevent user from sliding forward on seat (see Figure 34a).

To attach custom lumbar and seat support, remove seat and backrest pads, then read installation instructions provided with lumbar and seat support kit. Support padding may be cut or trimmed if necessary and affixed to seat with hook and loop strips. Replace seat and backrest pads when finished.

## Backrest filler pad

Backrest filler pad provides additional lower back support when chair backrest is high, creating an open space between backrest and seat (see Figure 34b).

To attach backrest filler pad, snap it into place on snap stud centered at bottom rear edge of backrest (see Figure 34c).



Figure 34a



Figure 34b

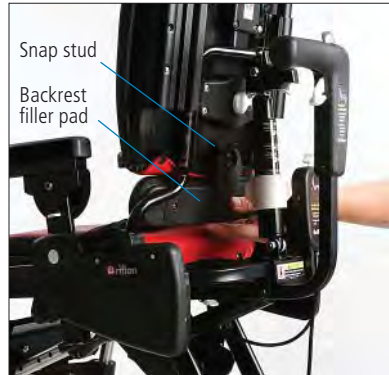

Figure 34c

## Tray

### **⚠️ WARNING**

To prevent falls, strangulation, head entrapment or other injuries, always use seatbelt or pelvic harness when the tray, chest straps, thigh belt, mini trunk support, or butterfly harness are in use.

The tray provides a work, play and feeding surface and adjusts in height, angle, and depth. A softly-rounded rim contains spills. Tray attaches to wooden armrests, not forearm supports.

To attach tray, first set both armrests to same height and angle. Pull black handle on tray and slide it onto armrests (see Figure 35a).

To adjust tray depth, pull black handle and slide tray forward or back. When desired place is reached, release handle and make sure tray audibly locks into place.

Adjust tray height and angle by adjusting armrest height and angle with tray attached (see page 11).

## Handhold

**Handhold can be attached anywhere along rim of tray to provide additional support and security.**

To attach and adjust handhold, loosen large oval knob and slide handhold along the tray until desired position is reached, then tighten knob securely (see Figure 35b).



Figure 35a

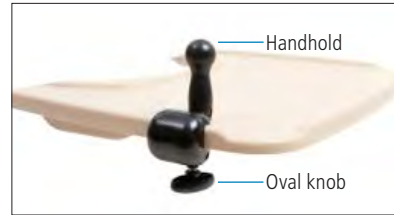

Figure 35b

## Push handles

**Push handles provide an ergonomic way for a caregiver to maneuver chair and transport user.**

There is a left and right push handle.

To attach push handle, press snap button at bottom of handle and insert it into one of the extrusions at rear of backrest. Since there is a left and right push handle, each handle will only fit into one side of chair (see Figure 36a).

To adjust push handle height, press snap button and move handle up and down until desired height is reached. Release button, making sure handle audibly locks into place.

## Footboard lift

**Footboard lifts** on the large and medium chairs add 4" (10 cm) of lift to the footboard.

Sandals and ankle straps can be used with all footboard lifts. Using the knobs provided, secure lift to footboard (see Figure 36b).

See pages 32 & 33 for instructions on how to attach ankle straps, sandals and wedges.

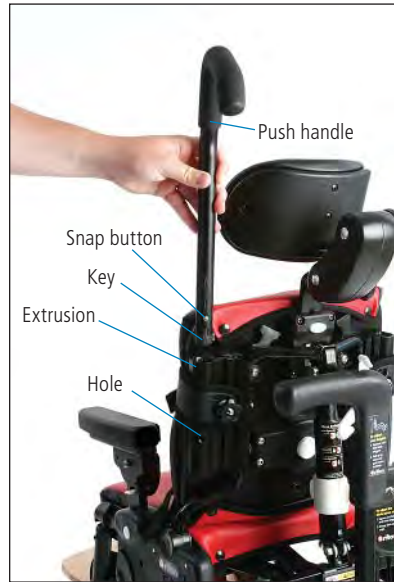

Figure 36a



Figure 36b Footboard lift

## Mini kit (R820 & R830 only)

**⚠ WARNING** To prevent falls, strangulation, head entrapment or other injuries:

- Always use seatbelt or pelvic harness when the tray, chest straps, thigh belt, mini trunk support, or butterfly harness are in use.
- Ensure correct adjustment and positioning of the mini trunk support at each use.

The three items in the mini kit make the small Activity Chair a prime option for the smallest child, from approximately 8 months up to 2 years (see Figure 37a). Remove it as the child grows to keep using the same chair for many more years.

**Mini footboard lift** adds 3" (8 cm) of height to the footboard.

**Mini trunk support** provides lateral and anterior support for user and can be adjusted in height and width (see figure 37b). To attach, loosen knobs (A) and insert the keys (B) into the extrusions (C) behind backrest. Slide knobs up and down until trunk support is at desired height. Tighten knobs firmly.

**Mini backrest insert** reduces the seat depth by 1" (3 cm). To install mini backrest insert, unsnap top edge of backrest pad, slide in insert, resnap pad (see Figure 37c).



Figure 37a



Figure 37b Mini trunk support



Figure 37c Mini backrest insert

## Maintenance 🛠️

This product is designed and tested for an expected life of 5 years when used and maintained in accordance with this manual. At all times, users must ensure that the product remains in a safe and useable condition, including regular maintenance and inspections as specified in this manual.

To prevent structural failure, which may result in serious injury or death:

- Inspect this product and accessories regularly for loose or missing screws, metal fatigue, cracks, broken welds, missing attachments, general instability or other signs of excessive wear.
- Immediately remove this product from use when any condition develops that might make operation unsafe.
- Do not use Rifton components or products for any purpose other than their intended use.
- Replace or repair components or products that are damaged or appear to be unstable.
- Use only Rifton authorized replacement parts. Order information for replacement parts is provided on the back of this product manual.

## Cleaning 🧑 🏠 🛠️

After each use, clean with disinfectant wipes or a solution of up to 10% bleach.

The upholstery should be cleaned in the same manner. You may also use a commercial cleaning agent suitable for imitation leather.

The straps with hook and loop closures may be laundered. Engage the closures before washing. Do not iron.

## Warranty Statement 🧑 🏠 🛠️

If a Rifton product breaks or fails in service during the first year, we will replace it free of charge.

# Materials

- Steel hardware items (nuts, bolts, screws, etc) are typically nickel plated, or stainless steel.
- Upholstery items (pads, support blocks, padded prompts, etc) are typically polyurethane foam with a fire-retardant cover made from expanded polyurethane.
- Frames are typically steel or aluminum tubing, welded together, and coated with a baked-on paint finish. Some frame components may also be stainless steel.
- Straps are typically made of polypropylene or nylon webbing.
- Wooden components are typically birch plywood, solid maple, or laminated hardwood veneers, finished with a clear polyurethane lacquer.
- Plastic components are typically injection molded from a variety of industrial resins.

All materials are latex, lead and phthalates free.

# User modifications

** WARNING** To prevent serious injury or death, do not modify or alter Rifton products or components, or use Rifton products or components in conjunction with products from other manufacturers. Rifton does not accept responsibility for any modifications or alterations made to our components or products after they leave our premises. Customers modifying or altering our components or products, or using them in conjunction with products from other manufacturers, do so at their own risk.