



QXi / QX

Quickie® QXi / QX

Supplier: This manual must be given to the rider of this wheelchair.

Rider: Before using this wheelchair read this entire manual and save for future reference.

Owner's Manual

SUNRISE MEDICAL LISTENS

Thank you for choosing a Quickie wheelchair. We want to hear your questions or comments about this manual, the safety and reliability of your chair, and the service you receive from your Sunrise supplier.

Be sure to return your warranty card, and let us know if you change your address. This will allow us to keep you up to date with information about safety, new products and options to increase your use and enjoyment of this wheelchair. If you lose your warranty card, call or write and we will gladly send you a new one.

FOR ANSWERS TO YOUR QUESTIONS

Your authorized supplier knows your wheelchair best, and can answer most of your questions about chair safety, use and maintenance. For future reference, fill in the following:

Supplier: _____

Address: _____

Telephone: _____

Serial #: _____ Date/Purchased: _____

ADDITIONAL INFORMATION YOU SHOULD KNOW

No component of this chair was made with Natural Rubber Latex.

**DISPOSAL AND RECYCLING INFORMATION**

When this product reaches the end of its life, please take it to an approved collection or recycling point designated by your local or state government. This wheelchair is manufactured using a variety of materials. Your product should not be disposed of as ordinary household waste. You should dispose of your wheelchair properly, according to local laws and regulations. Most materials that are used in the construction of this product are fully recyclable. The separate collection and recycling of your product at the time of disposal will help conserve natural resources and ensure that it is disposed in a manner that protects the environment.

Ensure you are the legal owner of the product prior to arranging for the product disposal in accordance with the above recommendations

USER WARNING

Attention wheelchair users, do not operate this wheelchair without first reading this owner's manual. If you do not understand the instructions and warnings of this owner's manual please contact your Authorized Dealer before operating this Quickie wheelchair. Failure to do so may result in damage and/or injury.

DEALER/TECHNICIAN WARNING

Attention dealers and qualified technicians, do not operate or service this wheelchair without first reading this owners manual. If you do not understand the instructions and warnings of this owners manual please contact the Quickie Technical Service Department before operating and/or servicing this Quickie wheelchair. Failure to do so may result in damage and/or injury.

I. INTRODUCTION	2	K Rear Wheel Locks	12
II. TABLE OF CONTENTS	3	L. Modified Seat Systems	12
III. YOUR CHAIR AND ITS PARTS	4	M.Seat and Back Upholstery	12
IV. NOTICE - READ BEFORE USE	4	VIII. USE AND MAINTENANCE	13
A. Choose the Right Chair & Safety Options	4	A. Introduction	13
B. Review This Manual Often	4	B. Critical Safety Checks.....	13
C. Warnings.....	4	C. Safety Checklist	13
V. GENERAL WARNINGS.....	5	D. Cleaning Tips	13
A. Weight Limits	5	E. Troubleshooting Chart.....	13
B. Intended Use.....	5	F. To Mount and Remove Rear Wheels	14
C. Attendants and Caregivers.....	5	G. Wheel Locks	14
D. Accessories	5	H. Anti-tips.....	14
E. Know Your Chair	5	I. Armrests.....	15
F. Reduce The Risk of an Accident	5	J. Dual-Post Flip-Back Height Adjustable Armrests or Flip-Back Height Adjustable Lite (Optional)	15
G. Safety Checklist	5	K. Padded Swing-away Armrests	16
H. Changes & Adjustments	5	L. Footrests, Legrests, & Footplates	16
I. Environmental Conditions	6	M. Elevating / Articulating Legrest (Optional)	17
J. Terrain	6	N. Seating and Seat Sling Upholstery.....	17
K. Street Use	6	O. Sideguards.....	17
L. Motor Vehicle Safety	6	P. Folding and Unfolding	18
M. When You Need Help	6	Q. Storage Tips.....	18
VI. SAFETY WARNINGS: FALLS & TIP-OVERS	7	R. Check-Out	18
A. Center of Balance	7	IX DEALER SERVICE AND ADJUSTMENT	20
B. Dressing or Changing Clothes	7	A. Dealer Service Introduction.....	20
C. Obstacles	7	B. Critical Maintenance tips	20
D. Front Caster Lift.....	7	C. Cleaning.....	20
E. Reaching or Leaning.....	7	D. Fixed Rear Axle-height adjustable (QX).....	20
F. Moving Backward.....	7	E. 3 Axis Adjustable Rear Axle System (QXi)	21
G. Escalators.....	8	F. Rear Wheel Axle Nut Adjustment	22
H. Ramps, Slopes & Sidehills	8	G. Wheel Locks	22
I. Transfer.....	9	H. Caster Forks	22
J. Curbs & Single Steps.....	9	I. Casters	23
K. Climbing a Curb or Single Step.....	10	J. Armrest Receiver Attachment	23
L. Descending a Curb or Single Step.....	10	K. Padded Swing-away Armrests	24
M. Stairs	10	L. Swing-in, Swing-out Hangers and Footrests	24
N. Climbing Stairs	10	M. Elevating / Articulating Legrest	24
O. Descending Stairs	10	N. Angle Adjustable Footplates	24
VII. WARNINGS: COMPONENTS & OPTIONS	11	O. Backrest.....	25
A. Anti-Tip Tubes	11	P. Angle Adjustable Backrest (Optional)	25
B. Armrests	11	Q. Seating and Seat Sling Upholstery	25
C. Cushion & Sling Seats	11	R. Removing the Seat Rail.....	25
D. Fasteners	11	S. Backrest Tension Adjustable	26
E. Footrests.....	11	T. Sideguard Hardware (Optional).....	26
F. Pneumatic Tires	11	U. Check-Out	26
G. Positioning Belts Option.....	12	X. SUNRISE LIMITED WARRANTY	27
H. Push Handles Option.....	12		
I. Quick-Release Axles	12		
J. Rear Wheels	12		

QUICKIE QXi



1. Backrest Tube
2. Backrest Upholstery
3. Rear Wheel /Tire
4. Handrim
5. Wheel rim
6. Anti-tip Tube
7. Quick-Release Axle
8. Axle Plate (Fixed QX or Adjustable QXi)
9. Caster Tire
10. Caster Fork
11. X-Hinge Caster Housing
12. Caster Housing
13. Swing-In/Swing-Out Latch Release
14. Flip-up Footplate
15. Swing-In / Swing-Out Hanger
16. Wheel Lock
17. Seat sling
18. Cushion
19. Padded Swing-Away Armrest

Note— All features may not be available with some chair setups or in conjunction with other chair features. Please consult your authorized supplier for more information.

IV. NOTICE— READ BEFORE USE

A. CHOOSE THE RIGHT CHAIR & SAFETY OPTIONS

Sunrise provides a choice of many wheelchair styles to meet your needs. This product is intended for single person use only. Final selection of the type of wheelchair, options and adjustments rests solely with you and your health care professional. Choosing the best chair for your unique mobility needs, will depend on such things as:

1. Your disability, strength, balance and coordination.
2. The types of hazards you must overcome in daily use (where you live and work, and other places you are likely to use your chair).
3. The need for options that will improve your positioning, safety and comfort (such as anti-tip tubes, positioning belts, or special seating systems).

B. REVIEW THIS MANUAL OFTEN

Before using this chair you, and each person who may assist you, should read this entire manual and make sure to follow all instructions. Review the warnings often, until they are second nature to you.

C. WARNINGS

The word “WARNING” refers to a hazard or unsafe practice that may cause severe injury or death to you or to other persons. The “Warnings” are in three main sections, as follows:

1. V — GENERAL WARNINGS

Here you will find a safety checklist and a summary of risks you need to be aware of before you ride this chair.

2. VI— SAFETY WARNINGS: FALLS & TIP-OVERS

Here you will learn about practices for the safe use of your chair, and how to avoid a fall or tip-over while you perform daily activities in your chair.

3. VII — WARNINGS — COMPONENTS & OPTIONS

Here you will learn about the components of your chair and options you can select for safety. Consult your authorized supplier and your health care advisor to help you choose the best set-up and options for safe use.

NOTE— Where they apply, you will also find “Warnings” in other sections of this manual. Heed all warnings in these sections. If you fail to do so a fall, tip-over or loss of control may occur and cause severe injury to the rider or others.

A. WEIGHT LIMITS**⚠ WARNING**

NEVER exceed the weight limit specified by Sunrise Medical. The weight capacity provided by your manufacturer is for the combined weight of a rider and items carried using on-board storage. If you do exceed the weight limit, damage to your chair, a fall, tip-over or loss of control may occur and cause severe injury to the rider or others.

Weight Capacities

Quickie QXi - 265lbs/(120kg).

B. INTENDED USE

The QXi wheelchair's intended use is to provide mobility to persons limited to a sitting position.

⚠ WARNING

DO NOT use this device for purposes other than what is intended by the manufacturer

1. The wheelchair is not designed for weight training and is unsafe for use as a seat while weight training. Weight training from the wheelchair substantially changes the stability of the chair and may cause tipping.
2. DO NOT stand on the frame of the wheelchair.
3. NEVER allow someone to stand on your chair or use it as a step ladder.
4. This chair is designed for a single rider only.
5. Unauthorized modifications and use of parts or accessories not supplied or approved by Sunrise Medical may change the chair structure. This will void the warranty and may cause a safety hazard. If the warning is ignored, damage to your chair, and the potential severe injury of the person using the chair for unintended purposes can occur.

C. ATTENDANTS AND CAREGIVERS**⚠ WARNING**

Before you assist a rider, be sure to read all warnings contained in this manual, and follow all instructions that apply. Be aware that after consulting a healthcare advisor, you will need to learn safe and proven body mechanics to use and create assistive methods best suited to your abilities.

D. ACCESSORIES**⚠ WARNING**

Unauthorized modifications or use of parts, or accessories not supplied or approved by Sunrise Medical may change the chair structure. This will void the warranty and may cause a safety hazard.

Some problems that may occur, but are not limited to:

1. Incorrect Wheels and/or tires that put the rider at risk of a fall or tip-over.
2. Adding a component to the frame, changing the structural integrity of the chair.
3. Any modification or disassembly can potentially create an unsafe situation where rider and/or attendant are put at risk.

E. KNOW YOUR CHAIR**⚠ WARNING**

Every wheelchair is different. Take the time to learn the feel of this chair before you begin riding. Start slowly, with easy, smooth strokes. If you are used to a different chair, you may use too much force and tip over. If you use too much force, damage to your chair, a fall, tip-over or loss of control may occur and cause severe injury to the rider or others.

F. REDUCE THE RISK OF AN ACCIDENT**⚠ WARNING**

1. BEFORE you begin riding, you should be trained in the safe use of this chair by your health care advisor.
2. Practice bending, reaching and transfers until you know the limit of your ability. Have someone help you until you know what can cause a fall or tip-over and how to avoid doing so.
3. Be aware that you must develop your own methods for safe use best suited to your level of function and ability.
4. NEVER try a new maneuver on your own. Ask the advice of your health care provider to lower the risk of a fall or tip over.
5. Get to know the areas where you plan to use your chair. Look for hazards and learn how to avoid them.

G. SAFETY CHECKLIST**⚠ WARNING**

Before Each Use Of Your Chair:

1. Make sure the chair rolls easily and that all parts work smoothly. Check for noise, vibration, or a change in ease of use. (This may indicate low tire pressure, loose fasteners, or damage to your chair).
2. Inspect any problem. Your authorized supplier can help you find and correct the problem.
3. Check to see that both quick-release rear axles are locked. When locked, the axle button will "pop out" fully. If not locked, the wheel may come off and cause you to fall.
4. If your chair has anti-tip tubes, lock them in place.

H. CHANGES & ADJUSTMENTS**⚠ WARNING**

1. See your healthcare advisor and have them adjust seating components any time a change or adjustment needs to be made.
2. Unauthorized modifications or use of parts not supplied or approved by Sunrise may change the chair structure. This will void the warranty and may cause a safety hazard.

If you fail to heed these warnings damage to your chair, a fall, tip-over or loss of control may occur and cause severe injury to the rider or others.

I. ENVIRONMENTAL CONDITIONS



⚠️ WARNING

1. Use extra care if you must ride your chair on a wet or slick surface. If you are in doubt, ask for help.
2. Contact with water or excess moisture may cause your chair to rust or corrode. Avoid all extreme weather situations if possible.
 - a. Do not use your chair in a shower, pool or other body of water. The chair tubing and parts are not water-tight and may rust or corrode from the inside.
 - b. Avoid excess moisture (for example, do not leave your chair in a damp bathroom while taking a shower).
 - c. Dry your chair as soon as you can if it gets wet, or if you use water to clean it.

If you fail to heed these warnings damage to your chair, a fall, tip-over or loss of control may occur and cause severe injury to the rider or others.

J. TERRAIN

⚠️ WARNING

1. Based on ANSI/RESNA testing, Sunrise Medical recommends the use of a caster wheel with a minimum diameter of 5", if the wheelchair will be overcoming obstacles up to 1/2" on a regular basis.
2. Your chair is designed for use on firm, even surfaces such as concrete, asphalt, indoor flooring, and carpets.
3. Do not operate your chair in sand, loose soil, or over rocky terrain.
4. If you use your chair on terrain that is rougher than described above there is a danger that screws and bolts will loosen prematurely, and that damage to wheels or axles could put the rider at risk of a fall, tip-over, or loss of control.

If you fail to heed these warnings damage to your chair, a fall, tip-over or loss of control may occur and cause severe injury to the rider or others.

K. STREET USE

⚠️ WARNING

1. This product is not intended for street use.
2. Avoid streets whenever possible.
3. Obey and follow all legal pedestrian pathways, and laws that apply to pedestrians.
4. Be alert to the danger of motor vehicles in parking lots, or if you must cross a road.

If you fail to heed this warning, damage to your chair, and a possible collision may occur and cause severe injury to the rider or others.

L. MOTOR VEHICLE SAFETY 1 2

If possible and feasible, the rider should transfer to the Original Equipment Manufacturer vehicle seat and use the OEM vehicle restraint.

Sunrise Medical does provide a Wheelchair Tie-Down and Occupant Restraint System, otherwise called a Transit Option. To Identify whether your wheelchair has been manufactured with the Transit Option installed, look for four points of securement. Two Front points (A), and two rear points (B). These points are recognized by the securement point decal which can be found on or near the securement points.

If your wheelchair is equipped with the Transit Option, please review this Transit Section carefully. You can call Sunrise medical at 1-800-333-4000 if you have any questions.

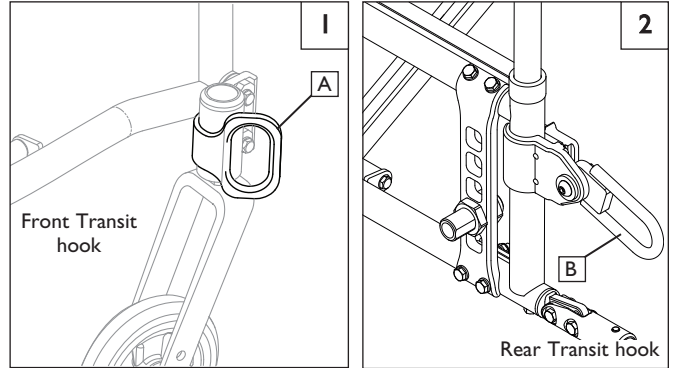

Look for this symbol on your wheelchair. It indicates wheelchair securement points which conform to ANSI/RESNA (1998) V.1 - Section 19.

⚠️ WARNING

If your chair is **NOT** equipped with the Transit Option:

1. NEVER let anyone sit in this chair while in a moving vehicle.
 - a. ALWAYS move the rider to an approved vehicle seat.
 - b. ALWAYS secure the rider with proper motor vehicle restraints.
2. In an accident or sudden stop the rider may be thrown from the chair. Wheelchair seat belts will not prevent this, and further injury may result from the belts or straps.
3. NEVER transport this chair in the front seat of a vehicle. It may shift and interfere with the driver.
4. ALWAYS secure this chair so that it cannot roll or shift.
5. Do not use any chair that has been involved in a motor vehicle accident. The frame and/or components may have been changed due to the accident. Such items could be, but are not limited to: bent, loosened, and/or broken components that were subjected to an impact.

Failure to heed these warnings puts you and others that may assist you at a high risk of injury.

M. WHEN YOU NEED HELP

⚠️ WARNING

For The Rider: Make sure that each person who helps you reads and follows all warnings and instructions that apply.

For Attendants:

1. Work with the rider's doctor, nurse or therapist to learn safe methods best suited to your abilities and those of the rider.
2. Tell the rider what you plan to do, and explain what you expect the rider to do. This will put the rider at ease and reduce the risk of an accident.
3. Make sure the chair has push handles. They provide secure points for you to hold the rear of the chair to prevent a fall or tip-over. Check to make sure push handle grips will not rotate or slip off.
4. To prevent injury to your back, use good posture and proper body mechanics. When you lift or support the rider or tilt the chair, bend your knees slightly and keep your back as upright and straight as you can.
5. Remind the rider to lean back when you tilt the chair backward.
6. When you descend a curb or single step, slowly lower the chair in one easy movement. Do not let the chair drop the last few inches to the ground. This may damage the chair or injure the rider.
7. To avoid tripping, unlock and rotate anti-tip tubes up, out of the way.
8. Whenever you aren't attending the wheelchair, ALWAYS use the wheel-lock to secure the rear wheels, and lock the anti-tip tubes in place.

If you fail to ask for help when in doubt, you run a high risk of a fall, tip-over or loss of control that may occur and cause severe injury to the rider or others

A. CENTER OF BALANCE**⚠ WARNING**

The point where this chair will tip forward, back or to the side depends on its center of balance and stability. How your chair is set up, the options you select and the changes you make may increase the risk of a fall or tip-over.

1. The Most Important Adjustment Is:
The position of the rear wheels. The more you move the rear wheels forward, the more likely your chair will tip over backward.
2. The Center Of Balance Is Also Affected By:
 - a. A change in the set-up of your chair, including:
 - The distance between the rear wheels.
 - The amount of rear wheel camber.
 - The seat height and seat angle.
 - Backrest angle.
 - b. A change in your body position, posture or weight distribution.
 - c. Riding your chair on a ramp or slope.
 - d. A back pack or other options and the amount of added weight.
3. To Reduce The Risk Of An Accident:
 - a. Consult your doctor, nurse or therapist to find out what axle and caster position is best for you.
 - b. Consult your authorized supplier BEFORE you modify or adjust this chair. Be aware that you may need to make other changes to correct the center of balance.
 - c. Have someone help you until you know the balance points of your chair and how to avoid a tip-over.
 - d. Use anti-tip tubes.

If you fail to heed these warnings, you are at a high risk of a fall, tip-over or loss of control that could cause severe injury to the rider or others.

B. DRESSING OR CHANGING CLOTHES**⚠ WARNING**

Your weight may shift if you dress or change clothes while seated in this chair.

- To reduce the risk of a fall or tip-over:
1. Rotate the front casters until they are as far forward as possible. This makes the chair more stable.
 2. Lock anti-tip tubes in place. (If your chair does not have anti-tip tubes, back it up against a wall and lock both rear wheels).

If you fail to heed this warning, damage to your chair, a fall, tip-over or loss of control may occur and cause severe injury to the rider or others.

C. OBSTACLES**⚠ WARNING**

Riding over curbs or obstacles can cause tipping and serious bodily harm. If you have any doubt that you can safely cross any curb or obstacle, ALWAYS ASK FOR HELP. Be aware of your riding skills and personal limitations. Develop new skills only with the help of a companion.

- To avoid the risk of traversing obstacles:
1. Keep a lookout for danger – scan the area well ahead of your chair as you ride.
 2. Make sure the floor areas where you live and work are level and free of obstructions.
 3. Remove or cover threshold strips between rooms.
 4. Install a ramp at entry or exit doors. Make sure there is not a drop off at the bottom of the ramp.
 5. To Help Correct Your Center Of Balance:
 - a. Lean your upper body FORWARD slightly as you go UP over an obstacle.
 - b. Press your upper body BACKWARD as you go DOWN from a higher to a lower level.
 6. If your chair has anti-tip tubes, do not go over an obstacle without help.

7. Keep both of your hands on the handrims as you go over an obstacle.
8. Never push or pull on an object (such as furniture or a doorjamb) to propel your chair.

If you fail to heed these warnings damage to your chair, a fall, tip-over or loss of control may occur and cause severe injury to the rider or others.

D. FRONT CASTER LIFT**⚠ WARNING**

Front caster lift can occur when the front wheels, ordinarily in contact with the ground, are either intentionally, or unintentionally caused to lift from the ground while the rear wheels remain in contact. Pitch control (partial or full) should NEVER be attempted without consulting your healthcare advisor and making sure that anti-tips are installed.

If you fail to heed this warning, you are at a high risk of damage to your chair, a fall, tip-over or loss of control that may occur and cause severe injury to the rider or others.

E. REACHING OR LEANING**⚠ WARNING**

If you reach or lean it will affect the center of balance of your chair. This may cause you to fall or tip over. When in doubt, ask for help or use a device to extend your reach.

1. NEVER reach or lean if you must shift your weight sideways or rise up off the seat.
2. NEVER reach or lean if you must move forward in your seat to do so. Always keep your buttocks in contact with the backrest.
3. NEVER reach with both hands (you may not be able to catch yourself to prevent a fall if the chair tips).
4. NEVER reach or lean to the rear unless your chair has anti-tip tubes locked in place.
5. DO NOT reach or lean over the top of the seat back. This may damage one or both backrest tubes and cause you to fall.
6. If You Must Reach Or Lean:
 - a. Do not lock the rear wheels. This creates a tip point and makes a fall or tip-over more likely.
 - b. Do not put pressure on the footrests.
 - c. Move your chair as close as you can to the object you wish to reach.
 - d. Do not try to pick up an object from the floor by reaching down between your knees. You are less likely to tip if you reach to the side of your chair.
 - e. Rotate the front casters until they are as far forward as possible. This makes the chair more stable.
 - f. Firmly grasp a rear wheel or an armrest with one hand. This will help to prevent a fall if the chair tips.

If you fail to heed these warnings damage to your chair, a fall, tip-over or loss of control may occur and cause severe injury to the rider or others.

F. MOVING BACKWARD**⚠ WARNING**

Use extra care when you move your chair backward. Your chair is most stable when you propel yourself forward. You may lose control or tip over if one of the rear wheels hits an object and stops rolling.

1. Propel your chair slowly and smoothly.
2. If your chair has anti-tip tubes, make sure to lock them in place.
3. Stop often and check to be sure your path is clear.

If you fail to heed this warning, you are at a high risk of damage to your chair, a fall, tip-over or loss of control that may occur and cause severe injury to the rider or others.

G. ESCALATORS

WARNING

NEVER use this chair on an escalator, even with an attendant. If you do, a fall or tip-over is likely.

If you fail to heed this warning you and others that may be assisting you, are at a high risk of severe injury.

H. RAMPS, SLOPES & SIDEHILLS 3 4 5 6

WARNING

Whenever possible, avoid riding on a slope, which includes a ramp or sidehill. This will change the center of balance of your chair. Your chair is less stable and more difficult to maneuver when it is at an angle. When moving up a hill, anti-tip tubes may not prevent a fall or tip-over.

1. **DO NOT** use your chair on a grade steeper than 10%. (A 10% grade means: one foot in elevation for every ten feet of slope length.)
2. **ALWAYS** go as straight up and as straight down as you can. (Do not “cut the corner” on a slope or ramp.)
3. **DO NOT** turn or change direction on a slope.
4. When you have to use a ramp, always stay in the CENTER of the ramp. Make sure ramp is wide enough that you have no risk of going off the edge.
5. **DO NOT** stop on a steep slope. If you stop, you may lose control of your chair.
6. **NEVER** use rear wheel locks to try to slow or stop your chair. This is likely to cause your chair to veer out of control.
7. **ALWAYS** be aware of:
 - a. Wet or slippery surfaces.
 - b. A change in grade on a slope (or a lip, bump or depression). These may cause a fall or tip-over.
 - c. A drop-off at the bottom of a slope or ramp. A drop-off as small as 3/4 inch can stop a front caster and cause the chair to tip forward.
8. To Reduce The Risk Of A Fall Or Tip-Over:
 - a. Lean or press your body UPHILL. This will help adjust for the change in the center of balance caused by the slope or sidehill.
 - b. Keep pressure on the handrims to control your speed on a down slope. If you go too fast you may lose control.
 - c. **ASK FOR HELP** any time you are in doubt.
9. Ramps At Home & Work— For your safety, ramps at home and work must meet all legal requirements for your area:
 - a. **AVOID A DROP-OFF**
Make sure there is a section at the top or bottom to smooth out the transition.
 - b. **ALWAYS** stay in the center of the ramp and control your speed.

If you fail to heed these warnings damage to your chair, a fall, tip-over or loss of control may occur and can possibly cause severe injury to the rider or others.

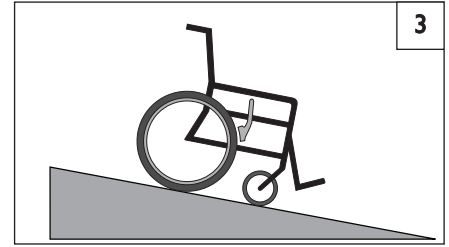

- IF** you need to go down a hill:
- a. The Downslope should be less than 6°.
 - b. **GO SLOW** Control your speed.
 - c. **ALWAYS** Go Straight down.
 - d. Never turn on a hill.
 - e. **ALWAYS** lean backward.

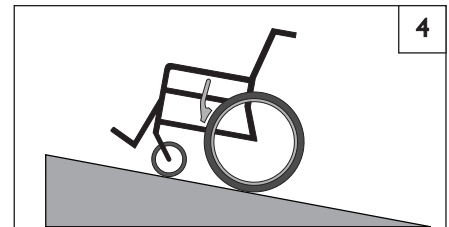

- IF** you need to go up a hill:
- a. The Upslope should be less than 6°.
 - b. **ALWAYS** Go Straight up.
 - c. **DON'T STOP**.
 - d. **NEVER** turn on a hill.
 - e. **ALWAYS** lean forward.

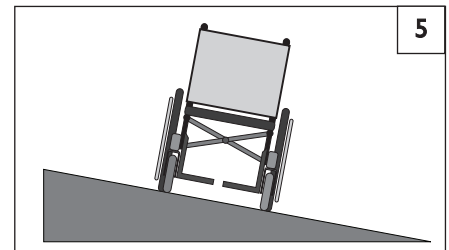

- IF** you need to traverse a Sidehill:
- a. The sidehill must be Less than 6° or you are at risk of a tip over.
 - b. **DON'T STOP**.
 - c. **NEVER** turn on a hill.

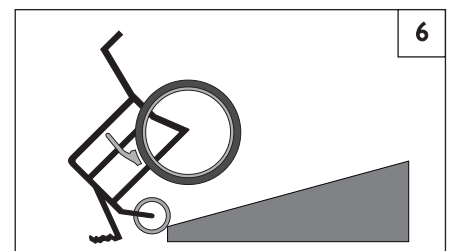

- If you need to traverse a Ramp:**
- a. Go Slowly.
 - b. **Watch out for Drop-offs.**
 - c. **ALWAYS** go straight up or straight down.
 - d. Stay centered on the Ramp.

I. TRANSFERS 7 8

⚠️ WARNING

It is dangerous to transfer on your own. It requires good balance and agility. Be aware that there is a point during every transfer when the wheelchair seat is not below you. To avoid a fall:

1. Work with your health care advisor to learn safe methods for transfers.
 - a. Learn how to position your body and how to support yourself during a transfer.
 - b. Have someone help you until you learn safe transfer methods.
2. Lock the rear wheels before you transfer.
3. Be aware that the chair can still slide and/or tip. The wheel lock keeps the rear wheels from rolling while you are performing the transfer.
4. Make sure that the pneumatic tires are properly inflated. Low tire pressure may allow the rear wheel locks to slip. (see table in Section G “Pneumatic Tires”)
5. Move your chair as close as you can to the seat you are transferring to. If possible, use a transfer board.
6. Rotate the front casters until they are as far forward as possible.
7. If you can, remove the footrests, or swing them out of the way.
 - a. Make sure your feet do not catch in the space between the footrests.
 - b. Avoid putting weight on the footrests as this may cause the chair to tip.
8. Make sure armrests are removed, or out of the way and do not interfere with the transfer.
9. Transfer as far back onto the seat surface as you can. This will reduce the risk that the chair will tip or move away from you.

Optimum Transfer position



- Before transferring:
1. Remove the armrests.
 2. Remove or move the footrests.
 3. Make sure the wheel lock is set.

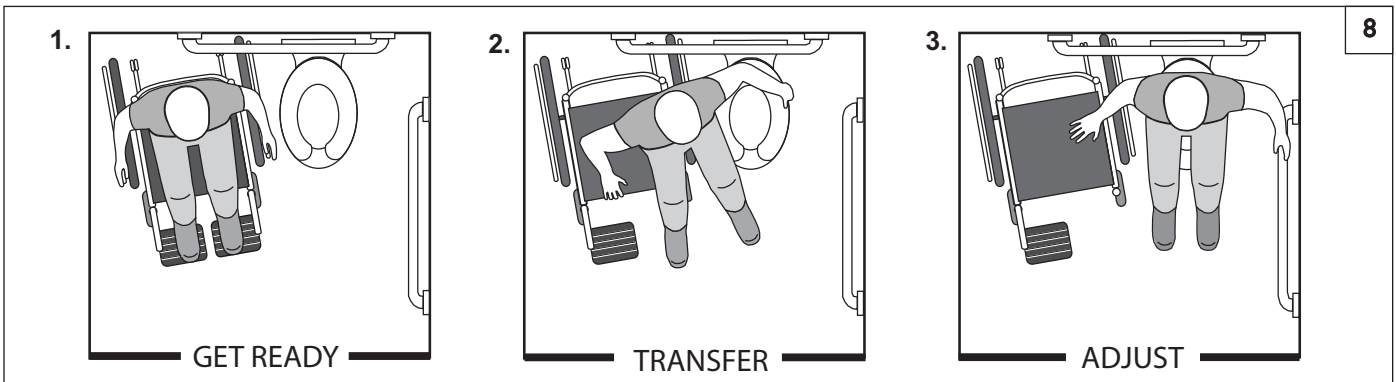

J. CURBS & SINGLE STEPS 9

⚠️ WARNING

Before riding over curbs, and negotiating even a single step, ALWAYS ask for assistance first. Curbs and steps can cause tipping and serious bodily harm. When in doubt as to your ability to avoid, or traverse any obstacle, always ask for help. Be aware of your riding skills and personal limitations. Develop new skills only with the help of a companion.

- For Attendant:** Each person who assists the rider with curbs and steps should read and follow all instructions and warnings pertaining to attendants, and caregivers.
1. Do not try to climb a high curb or step (more than 4 inches high) UNLESS you have help. Doing so may cause your chair to exceed its balance point and tip over.
 2. Go straight up and straight down a curb or step. If you climb or descend at an angle, a fall or tip-over is likely.
 3. Be aware that the impact of dropping down from a curb or step can damage your chair or loosen fasteners.

If you fail to heed these warnings damage to your chair, a fall, tip-over or loss of control may occur and can possibly cause severe injury to the rider or others.

K. CLIMBING A CURB OR SINGLE STEP 9**⚠ WARNING**

For Attendant: follow these steps to help the rider climb a curb or single step going **BACKWARD**:

1. Stay behind the chair.
2. Continue backward until the rear wheels contact the face of the curb or step. Lift and roll the rear wheels to the top of the curb.
3. Pull the chair backwards until the caster wheels have cleared the edge of the curb and return the chair to its rolling position.

If you fail to heed these warnings damage to your chair, a fall, tip-over or loss of control may occur and cause severe injury to the rider or others.

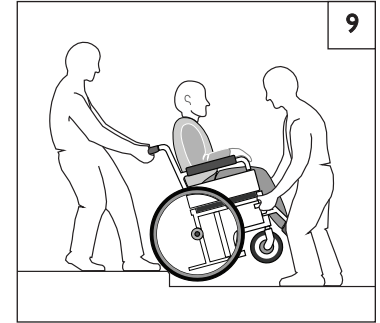
**L. DESCENDING A CURB OR SINGLE STEP** 9**⚠ WARNING**

For Attendant: Follow these steps to help a rider descend a curb or single step going **FORWARD**:

1. Stay at the rear of the chair.
2. Several feet before you reach the edge of the curb or step, tip the chair slightly and pull it backward.
3. When the chair is at its balance point, carefully step forwards until the rear wheels reach the edge of the curb or step. Then allow the rear wheels to slowly roll down onto the lower level.
4. Push the chair forward until you are standing on the lower level.
5. When the rear wheels are safely on the lower level, tilt the chair back to its balance point.

If you fail to heed these warnings damage to your chair, a fall, tip-over or loss of control may occur and cause severe injury to the rider or others.

M. STAIRS 10**⚠ WARNING**

1. NEVER use this chair on stairs UNLESS you have someone to help you. Doing so is likely to cause a fall or tip-over.
2. Negotiating stairs with a wheelchair always requires at least 2 attendants for safety.

If you fail to heed these warnings damage to your chair, a fall, tip-over or loss of control may occur and cause severe injury to the rider or others.

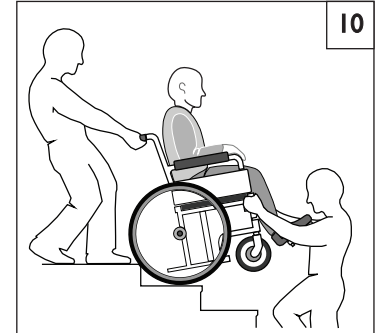
**N. CLIMBING STAIRS** 10**⚠ WARNING**

1. Use at least two attendants to move a chair and rider up stairs.
2. Move the chair and rider **BACKWARD** up the stairs.
3. The person at the rear is in control. He or she tilts the chair back to its balance point.
4. A second attendant at the front firmly grasps a non-detachable part of the front frame and lifts the chair up and over one stair at a time.
5. The attendants move to the next stair up. Repeat for each stair, until you reach the landing.

If you fail to heed these warnings damage to your chair, a fall, tip-over or loss of control may occur and cause severe injury to the rider or others.

O. DESCENDING STAIRS 10**⚠ WARNING**

1. Use at least two attendants to move a chair and rider down stairs.
2. Move the chair and rider **FORWARD** down the stairs.
3. The person at the rear is in control. He or she tilts the chair to the balance point of the rear wheels and rolls it to the edge of the top step.
4. A second attendant stands on the third step from the top and grasps the chair frame. He or she lowers the chair one step at a time by letting the rear wheels roll over the stair edge.
5. The attendants move to the next stair down. Repeat for each stair, until you reach the landing.

If you fail to heed these warnings damage to your chair, a fall, tip-over or loss of control may occur and cause severe injury to the rider or others.

A. ANTI-TIP TUBES



Anti-tip tubes can help keep your chair from tipping over backward in normal conditions.

1. Sunrise recommends the use of anti-tip tubes:
2. When locked in place (in the “down” position) anti-tip tubes should be BETWEEN 1 1/2 to 2 inches off the ground.
 - a. If set **higher** than 2 inches, they may not prevent a tip-over.
 - b. If set **lower** than 2 inches, they may “hang up” on obstacles and cause a fall or tip over.
3. If you have to climb or descend a curb, or overcome an obstacle it may be necessary to have an attendant make sure the anti-tip tubes are rotated up, and out of the way, so that the chair and rider do not get stuck and/or become unstable.

If you fail to heed these warnings damage to your chair, a fall, tip-over or loss of control may occur and cause severe injury to the rider or others.

B. ARMRESTS



Armrests detach and will not bear the weight of this chair.

1. NEVER lift this chair by its armrests. They may come loose or break.
2. Lift this chair only by non-detachable parts of the main frame.

If you fail to heed these warnings damage to your chair, a fall, tip-over or loss of control may occur and cause severe injury to the rider or others.

C. CUSHIONS & SLING SEATS



1. Quickie sling seats and standard foam cushions are not designed for the relief of pressure.
2. If you suffer from pressure sores or if you are at risk that they will occur, you may need a special seat system or a device to control your posture. Consult your doctor, nurse or therapist to find out if you need such a device for your well-being.
3. Seat slings are not intended to be used as a direct seating surface. A cushion or other seating surface should be placed on the sling before use.

If you fail to heed these warnings damage to your chair, a fall, tip-over or loss of control may occur and cause severe injury to the rider or others.

D. FASTENERS



Many of the screws, bolts and nuts on this chair are special high-strength fasteners. Use of improper fasteners may cause your chair to fail.

1. ONLY use fasteners provided by an authorized supplier (or ones of the same type and strength, as indicated by the markings on the heads).
2. Over- or under-tightened fasteners may fail or cause damage to chair parts.
3. If bolts or screws become loose, tighten them as soon as you can.

If you fail to heed these warnings damage to your chair, a fall, tip-over or loss of control may occur and cause severe injury to the rider or others.

E. FOOTRESTS



1. At the lowest point, footrests should be AT LEAST 2 inches off the ground. If set too LOW, they may “hang up” on obstacles you can expect to find in normal use. This may cause the chair to stop suddenly and tip forward.
2. To Avoid A Trip Or Fall When You Transfer:
 - a. Make sure your feet do not “hang up” or get caught in the space between the footrests.
 - b. Avoid putting weight on the footrests, as the chair may tip forward.
 - c. Footrests should be swung out of the way or removed whenever entering or exiting the wheelchair.
3. NEVER lift this chair by the footrests. Footrests detach and will not bear the weight of this chair. Lift this chair only by non-detachable parts of the main frame.\
4. Never use the footrests of the chair to open doors, this may cause them to fail prematurely, and create an unsafe situation.

If you fail to heed these warnings damage to your chair, a fall, tip-over or loss of control may occur and cause severe injury to the rider or others.

F. PNEUMATIC TIRES II



Proper inflation extends the life of your tires and makes your chair easier to use.

1. Do not use this chair if any of the tires are under- or over-inflated. Check weekly for proper inflation level, as listed on the tire side-wall.
2. Low pressure in a rear tire may cause the wheel lock on that side to slip and allow the wheel to turn when you do not expect it.
3. Low pressure in any of the tires may cause the chair to veer to one side and result in a loss of control.
4. Over-inflated tires may burst.

If you fail to heed these warnings damage to your chair, a fall, tip-over or loss of control may occur and cause severe injury to the rider or others.

Recommended Tire Pressures		Recommended Pressure or Pressure Range	
		kPa	PSI
Tires	Quickie Qxi		
Pneumatic - 20"	x	448	65
Pneumatic - 22"	x	448	65
Pneumatic - 24"	x	517	75
Pneumatic - 26"	x	448	65
High Pressure Clincher (22")	x	690	100
High Pressure Clincher (24")	x	758	110
High Pressure Clincher (25")	x	758	110
High Pressure Clincher (26")	x	758	110

G. POSITIONING BELTS (Optional)**⚠ WARNING**

Use positioning belts **ONLY** to help support the rider's posture. Improper use of these belts may cause severe injury to or death to the rider.

1. Make sure the rider does not slide down in the wheelchair seat. If this occurs, the rider may suffer chest compression or suffocate due to pressure from the belts.
2. The belts must be snug, but must not be so tight that they interfere with breathing. You should be able to slide your open hand, flat, between the belt and the rider.
3. A pelvic wedge or a similar device can help keep the rider from sliding down in the seat. Consult with the rider's doctor, nurse or therapist to find out if the rider needs such a device.
4. Use positioning belts only with a rider who can cooperate. Make sure the rider can easily remove the belts in an emergency.
5. NEVER Use Positioning Belts:
 - a. As a patient restraint. A restraint requires a doctor's order.
 - b. On a rider who is comatose or agitated.
 - c. As a motor vehicle restraint. In an accident or sudden stop the rider may be thrown from the chair. Wheelchair seat belts will not prevent this, and further injury may result from the belts or straps.

If you fail to heed these warnings damage to your chair, a fall, tip-over or loss of control may occur and cause severe injury to the rider or others.

H. PUSH HANDLES (Optional)**⚠ WARNING**

When you have an attendant, make sure that this chair has push handles.

1. Push handles provide secure points for an attendant to hold the rear of this chair, to prevent a fall or tip-over.
2. Check to make sure push handle grips will not rotate or slip off.

If you fail to heed these warnings damage to your chair, a fall, tip-over or loss of control may occur and cause severe injury to the rider or others.

I. QUICK-RELEASE AXLES**⚠ WARNING**

1. Do not use this chair **UNLESS** you are sure that both quick-release rear axles are locked.
2. An axle is not locked until the quick-release button pops out fully.
3. An unlocked axle may come off during use, resulting in a fall, tip-over or loss of control and cause severe injury to the rider or others.
 - Quick-Release Axles should be periodically cleaned and inspected for function and signs of wear or bending. Replace as necessary.

If you fail to heed these warnings damage to your chair, a fall, tip-over or loss of control may occur and cause severe injury to the rider or others.

J. REAR WHEELS**⚠ WARNING**

A change in set-up of the rear wheels will affect the center of balance of your chair.

1. The farther you move the rear axles **FORWARD**, the more likely it is that your chair will tip over backward.
2. Consult your healthcare advisor to find the best rear axle set-up for your chair. Do not change the set-up **UNLESS** you consult your healthcare advisor first.
3. Adjust the rear wheel locks after you make any change to the rear axles.
 - a. If you fail to do so, the wheel locks may not work.
 - b. Make sure lock arms embed in the tires at least 1/8 inch when locked.

If you fail to heed these warnings damage to your chair, a fall, tip-over or loss of control may occur and cause severe injury to the rider or others.

K. REAR WHEEL LOCKS**⚠ WARNING**

Rear wheel locks are **NOT** designed to slow or stop a moving wheelchair. Use them only to keep the rear wheels from rolling when your chair is at a complete stop.

1. **NEVER** use rear wheel locks to try to slow or stop your chair when it is moving. Doing so may cause a fall or tip-over.
2. To keep the rear wheels from rolling, always set both rear wheel locks when you transfer to or from your chair.
3. Low pressure in a rear tire may cause the wheel lock on that side to slip and may allow the wheel to turn when you do not expect it.
4. Make sure lock arms embed in tires at least 1/8 inch when locked. If you fail to do so, the locks may not work.

If you fail to heed these warnings damage to your chair, a fall, tip-over or loss of control may occur and cause severe injury to the rider or others.

L. MODIFIED SEAT SYSTEMS**⚠ WARNING**

Use of a seat system not approved by Sunrise may alter the center of balance of this chair. This may cause the chair to tip over.

1. Do not change the seat system of your chair **UNLESS** you consult your authorized supplier first.
2. Use of a seating system not approved by Sunrise may affect the folding mechanism of this chair.
3. Use of a seating system not provided by Sunrise is prohibited for transit use.

If you fail to heed these warnings damage to your chair, a fall, tip-over or loss of control may occur and cause severe injury to the rider or others.

M. SEAT AND BACK UPHOLSTERY**⚠ WARNING**

1. Replace worn or torn fabric of seat and seat back as soon as you can. If you fail to do so, the seat or seat back may fail.
2. Sling fabric will weaken with age and use. Look for fraying, thin spots, or stretching of fabrics especially at edges and seams.
3. "Dropping down" into your chair will weaken fabric and result in the need to inspect and replace the seat more often.
4. Be aware that laundering or excess moisture will reduce the flame retardation qualities of the fabric.
5. If Tension Adjustable upholstery is present, loosen straps or remove upholstery prior to folding or unfolding the chair.

If you fail to heed these warnings damage to your chair, a fall, tip-over or loss of control may occur and cause severe injury to the rider or others.

⚠ WARNING

The owner of this chair is responsible for making sure that it has been setup and adjusted by a trained service professional under the advice of a healthcare advisor. The chair may require periodic safety and function checks or certain in-use adjustments that may be performed by the owner or caregiver. Always use parts and/or accessories that have been recommended or approved by Sunrise Medical when servicing this chair.

A. INTRODUCTION

1. Proper maintenance will improve performance and extend the useful life of your chair.
2. Clean your chair regularly. This will help you find loose or worn parts and make your chair easier to use. You will need a mild detergent solution and plenty of cleaning rags.
3. If discovered, repair or replace loose, worn, bent or damaged parts **before using the chair**. ALWAYS be sure to use Parts and/or accessories that have been recommended or approved by Sunrise Medical.
4. To protect your investment, have all major maintenance and repair work done by your authorized dealer.
5. **Inspect and maintain this chair strictly per the maintenance chart.**
6. **If you detect a problem, make sure to order parts, or have service, and repair work done at your authorized dealer before use.**
7. **At least once per year, have a complete inspection, safety check, and service of your chair made by an authorized dealer.**

B. CRITICAL SAFETY CHECKS

1. Tire Air Pressure:

Check air pressure in pneumatic tires at least **ONCE PER WEEK**. The wheel locks will not grip properly if you fail to maintain the air pressure shown on tire sidewall.

C. SAFETY CHECKLIST

Weekly	3 Months	6 Months	Annually	Safety and Function Check...
<input checked="" type="checkbox"/>				Tire inflation level
<input checked="" type="checkbox"/>				Wheel locks
	<input checked="" type="checkbox"/>			Visually check for loose hardware
		<input checked="" type="checkbox"/>		Armrests
		<input checked="" type="checkbox"/>		Axle and axle sleeves
	<input checked="" type="checkbox"/>			Quick-release axles
	<input checked="" type="checkbox"/>			Wheels, tires and spokes
	<input checked="" type="checkbox"/>			Casters
	<input checked="" type="checkbox"/>			Anti-tip tubes
		<input checked="" type="checkbox"/>		Frame Camber tubes and crossbrace
	<input checked="" type="checkbox"/>			Upholstery
			<input checked="" type="checkbox"/>	Service by Authorized Supplier

NOTE - The user or caregiver should perform these weekly and monthly checks to maintain the safety of their chair. If an item is not working properly, please contact your authorized dealer.

2. Axles & Axle Sleeves:

When checking axles and axle sleeves every six months, make sure they are clean and tight. Loose sleeves will damage the axle plate and will affect performance.

D. CLEANING TIPS

1. Paint Finish

- a. Clean the painted surfaces with mild soap or detergent at least once a month.
- b. Protect the paint with a coat of non-abrasive auto wax every three months.

2. Axles and Moving Parts

- a. Clean around axles and moving parts **WEEKLY** with a slightly damp (not wet) cloth.
- b. Wipe off or blow away any fluff, dust or dirt on axles or moving parts.

3. Upholstery

- a. Hand-wash (machine washing may damage fabric).
- b. Drip-dry only. **DO NOT** machine dry as heat will damage fabric.

4. Basic Maintenance Materials available at local store

- a. Tire Pump
- b. Tire pressure Gauge
- c. Clean rags or cotton cloth.
- d. Teflon-based Lubricant
- e. Mild Detergent.

NOTE– You do not need to grease or oil the chair.

E. TROUBLESHOOTING CHART

Symptom	Symptom						Solution
	Left turn in chair	Right Turn in chair	Looseness in chair	Sluggish turning	Squeaks and rattles	Caster flutter	
<input checked="" type="checkbox"/>	<input checked="" type="checkbox"/>	<input checked="" type="checkbox"/>	<input checked="" type="checkbox"/>	<input checked="" type="checkbox"/>			Make sure tire pressure is correct and equal in both rear tires and front caster tires, if pneumatic.
			<input checked="" type="checkbox"/>	<input checked="" type="checkbox"/>	<input checked="" type="checkbox"/>	<input checked="" type="checkbox"/>	Make sure all nuts and bolts are tight.
			<input checked="" type="checkbox"/>		<input checked="" type="checkbox"/>		Make sure all spokes and nipples are tight on radial spoke wheels.
					<input checked="" type="checkbox"/>		Use Tri-Flow Lubricant (Teflon®-based) between frame connections and parts.
<input checked="" type="checkbox"/>	<input checked="" type="checkbox"/>		<input checked="" type="checkbox"/>			<input checked="" type="checkbox"/>	Check for proper caster fork adjustment. See instructions for caster fork adjustment.

F. TO MOUNT & REMOVE REAR WHEELS 12 13 14**⚠ WARNING**

Do not use this chair UNLESS you are sure both quick-release axles are locked. An unlocked axle may come off during use and cause a fall.

1. To Install Wheel

- Depress quick-release button (A) fully. This will release tension on ball bearings at other end.
- Insert axle (B) through hub of rear wheel.
- Keep button (A) depressed as you slide axle (B) into axle sleeve (C).
- Release button to lock axle in axle sleeve. Adjust axle if it does not lock. See Section B.
- Repeat steps on other side.

NOTE—The axle is not locked until the quick-release button pops out fully (A). The detent button (D) on the end of the Axle needs to be exposed on the other side of the Axle Sleeve (D). Check that the axle is locked by pulling on the wheel in the direction of the axle.

2. To Remove Wheel

- Depress quick-release button (A) fully.
- Remove wheel by sliding axle (B) completely out of axle sleeve (C).
- Repeat steps on other side.

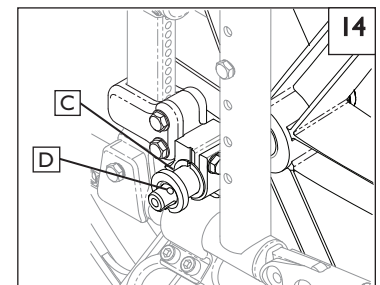
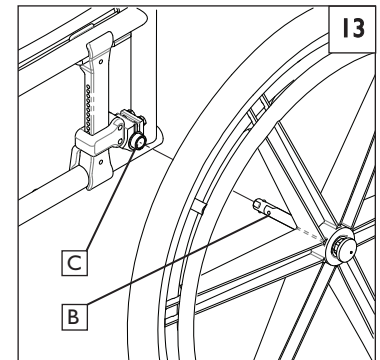
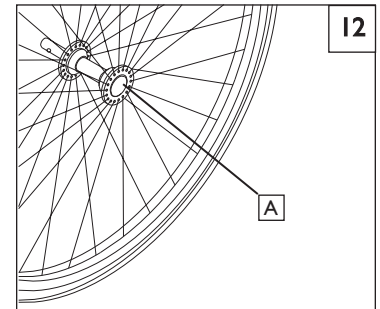
**G. WHEEL LOCKS** 15**⚠ WARNING**

Wheel locks are installed at Sunrise and should be adjusted by your qualified service person.

Inspect wheel locks weekly per the maintenance chart. Do not use your chair UNLESS you are sure both wheel-locks can fully engage. A wheel-lock that is not correctly adjusted may allow your chair to roll, or turn unexpectedly.

Wheel-locks must be adjusted after making sure the tires have the correct air pressure. When fully engaged, the arm should be imbedded into the tire at least 1/8" to be effective.

If you find the wheel locks have slipped or are not working correctly contact your service provider for proper adjustment.

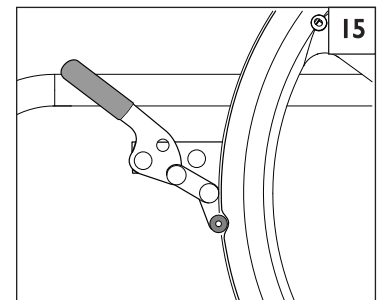
**H. ANTI-TIPS** 16 17 18

Sunrise Medical recommends anti-tip tubes for all wheelchairs.

1. Inserting Anti-Tip Tubes Into Receiver 16

- Press the rear anti-tip release pin (E) on the anti-tip tube so that both release pins are drawn inside.
- Insert into the anti-tip tube into the receiver (F).
- Turn the anti-tip tube down until release pin is positioned through the receiver mounting hole.
- Insert second anti-tip tube the same way

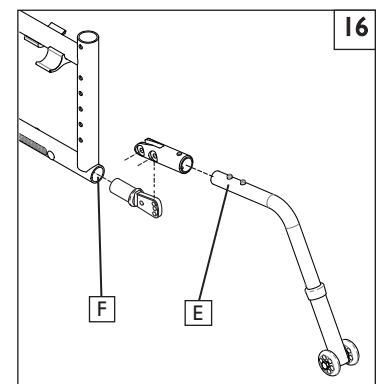

2. Adjusting Anti-Tip Tube Wheel 17

The anti-tip tube wheels may have to be raised or lowered to achieve proper clearance | 1/2" to 2".

- a. Press the anti-tip wheel release pin(A) so that the release pin is drawn inside.
- b. Raise or lower to one of the three predrilled holes.
- c. Release pin.
- d. Adjust the second anti-tip tube wheel the same way. Both wheels should be at exactly the same height.

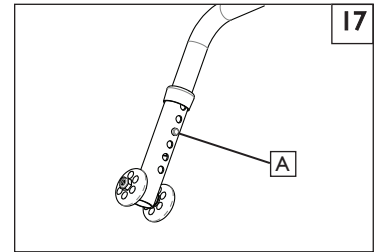

3. Turning Anti-Tip Tubes Up 18

Turn anti-tip tubes up when being pushed by attendant, overcoming obstacles or climbing curbs.

- a. Press the rear anti-tip tube release pin (B).
- b. Hold pin in and turn anti-tip tube up.
- c. Release pin, and make sure the anti-tip is locked in place.
- d. Repeat these steps with second anti-tip tube.

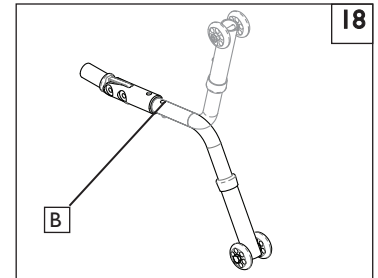

I. ARMRESTS 19

Sunrise medical offers several different types of armrests. Fixed, swing-away, and Flip-back armrests. Flip-back armrests can be detached or can flip back to allow lateral transfers. They are height adjustable (1" increments) by flipping the adjustment lever and moving the armrest pad (1) up or down to the desired height.

1. Basic Installation

- a. Slide the outer armpost (4) into the receiver mounted to the wheelchair frame.
- b. The armrest should lock into place.

2. Height Adjustment

- a. Release the upper securing lever (2) .
- b. Slide armpad up or down to desired height.
- c. Return lever to locked position.

3. Removing Armrest

- a. To remove, grasp the unlocking lever (3) and pull up on the Armrest.

4. Replacing Armrest

- a. Slide armrest back into receiver.
- b. Make sure that the unlocking lever (3) returns to the locked position against armpost

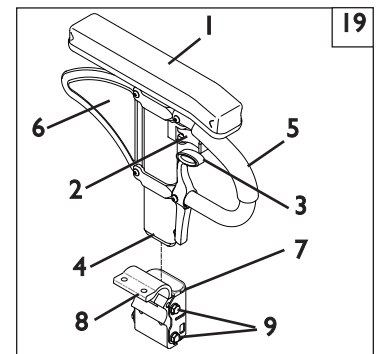

1. Armrest pad
2. Height Release Lever
3. Release lever
4. Outer armpost
5. Transfer bar
6. Side panel
7. Receiver
8. Clamp
9. Receiver adjustment hardware

J. DUAL-POST FLIP-BACK HEIGHT-ADJUSTABLE ARMRESTS (Optional) 20 21
OR FLIP-BACK HEIGHT-ADJUSTABLE LITE (Optional)

Flip-back height adjustable armrests are installed at Sunrise.

1. Height Adjustment 20

- a. Release the upper securing lever.
- b. Slide armpad up or down to desired height.
- c. Return lever to locked position.

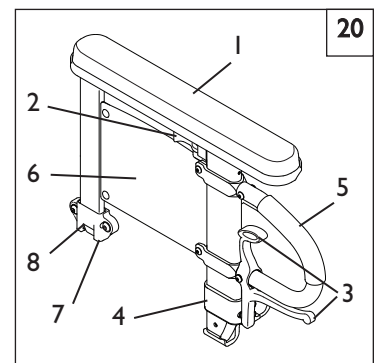

1. Armrest Pad
2. Upper Securing Lever
3. Release Latch
4. Front Receiver
5. Transfer bar Rear Receiver
6. Armrest Panel
7. Rear Receiver
8. Armrest Release Pin

2. Flipping Armrest Back and Removing Armrest 21

- a. Depress the release latch (3) and pull arm toward back of wheelchair.
- b. To remove, pull up on armrest. Pin securing armrest will automatically release.
- c. To return armrest to operating position, push armpad down (1) until it locks firmly into place.

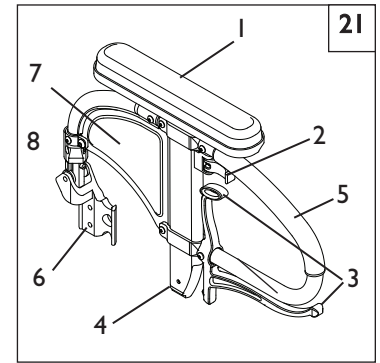

1. Armrest Pad
2. Upper Securing Lever
3. Release Latch
4. Outer armpost Armrest Panel
5. Transfer bar
6. Rear Receiver
7. Armrest Panel
8. Armrest Release Pin

K. PADDED SWING-AWAY ARMRESTS 22

Swing-away armrests can be detached or can swing away to allow lateral transfers. Swing-away, removable armrests are installed by sliding armrest (A) into receiver (B) on back frame.

NOTE –To avoid armrests that are angled inward or outward when seated in the wheelchair ensure receiver hardware is mounted onto the frame so that the hardware is perpendicular to the frame thus properly aligning the armrest when installed into the receiver.

1. Installation

Slide armrest into receiver tube (A) on rear of frame.

2. Swinging Away

Lift armrest out of locked position and rotate to the side.

3. Removing Armrest

Pull armrest straight out of receiver.

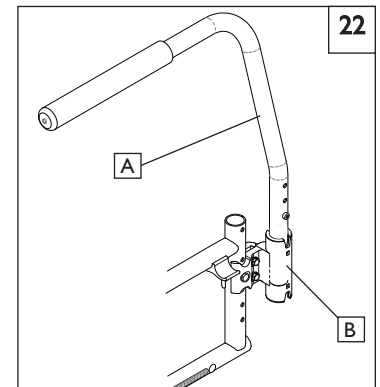
**L. FOOTRESTS, LEGRESTS, & FOOTPLATES** 23

Make sure that your Sunrise dealer has correctly adjusted your footrests and/or legrests with the advice of a healthcare professional. The original setup should not be changed without first checking with that advisor. The footrest position is key to keeping your body in the proper alignment, and providing a stable support for your legs and torso. Legrests and footrests should be swung out of the way, or removed for transfers.

Swing-in-Swing-out Hangers and Footrests (60°, 70°, 80°)

1. Basic Footrest Installation

- a. Place swing-in/swing-out pivot saddle into the receiver (C) on front frame tube with the footrest facing inward or outward from the frame.
- b. Rotate the footrest inward until it locks into place on locking plate.

2. Removal

- a. To remove footrest, release latch (D) by pulling lever upward or pushing lever downward.
- b. Rotate footrest inward or outward and lift.

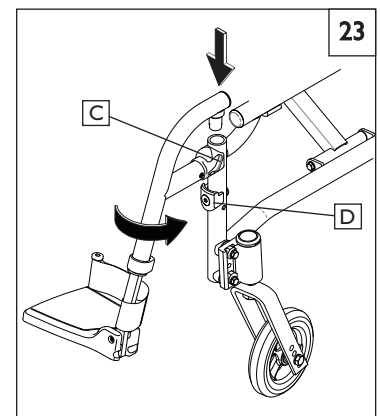

M. ELEVATING / ARTICULATING LEGREST (Optional) 24a 24b**1. Installation or Removal**

To install or remove Elevating / Articulating Legrest see instructions for Swing-away Footrest installation.

2. Elevation Adjustment

- To raise legrest, lift to desired position. Legrest will automatically lock in place.
- To lower legrest, while seated in chair, press release lever (A) down and lower Legrest to desired position. Legrest will automatically lock in place.

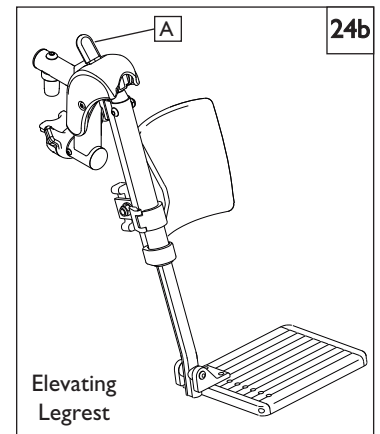
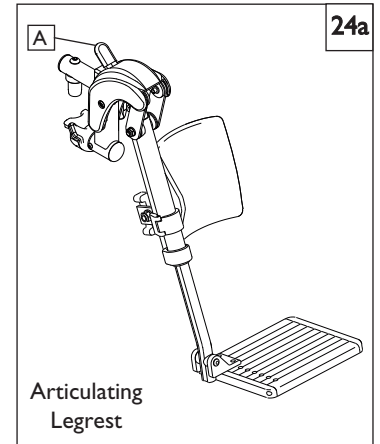
**N. SEATING AND SEAT SLING UPHOLSTERY** 25

The seat sling can be adjusted through the use of hook and loop material (B) beneath the seat. Seat sling also includes a folding strap on the seat to assist in folding the chair.

NOTE- The seat sling folding strap is not intended as a carrying strap.

1. Seat sling Upholstery

- Check monthly for excessive stretching of the upholstery, or loose attaching hardware. If you determine the upholstery can no longer be adjusted tight, contact your service representative for a replacement.

2. Cushion Installation

- Place cushion on the seat sling with hook material side down. The beveled edge of the cushion should be facing toward the front of your chair.
- Press firmly into place.

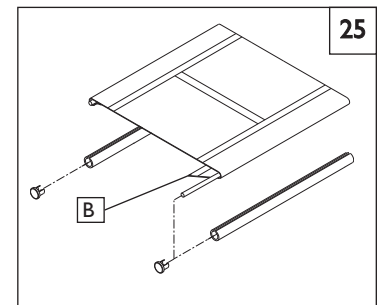
**O. SIDE GUARDS** 26**Inserting and Removing the Side Guard**

- Insert the Side Guard(C) into Side Guard(D) outer receiver hardware
- To Remove, grip the top of the Side Guard and pull upward.

NOTE- After installing receiver hardware and inserting the side guard, check for interference. Don't operate the wheelchair if the sideguard interferes with any of the other components.

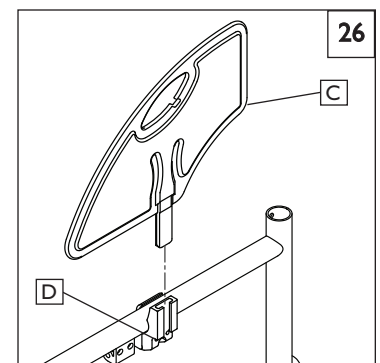

P. FOLDING AND UNFOLDING

WARNING

Possible pinch point! BE CAREFUL.

1. If seat sling is not present during folding or unfolding, pinch top of seat rail securely without wrapping fingers around the seat rail.
2. Use flat palms to depress the chair if opening.

WARNING

IF YOU HAVE TENSION ADJUSTABLE UPHOLSTERY,
loosen straps or remove upholstery prior to folding or unfolding the chair.

1. Folding the Wheelchair

- a. Remove quick-release wheels (optional).
 - Depress quick-release button on the axle.
 - Remove wheel by sliding out quick-release axle from axle bracket.
 - Repeat with other wheel.
- b. For the Swing Away model, flip up the footrest to a vertical position before folding the wheelchair.
- c. Grasp the seat sling (in the center) and lift sharply until the wheelchair is folded.

2. Unfolding the Wheelchair

- a. Replace quick-release wheel (optional) by depressing the quick-release button on the axle.
- b. Slide it into the axle sleeve until it locks.
- c. Repeat with other wheel.
- d. Tilt the wheelchair toward you far enough to take the weight off the opposite wheel.
- e. Push down on the seat rail (closest to you) until the wheelchair is completely opened.
- f. Make sure seat rail tubes are resting in the seat rail saddles.

NOTE— Ensure that footrests are locked prior to use.

Q. STORAGE TIPS

1. Store your chair in a clean, dry area. If you fail to do so, parts may rust or corrode.
2. Before using your chair, make sure it is in proper working order. Inspect and service all items on the “Maintenance Chart”.
3. If stored for more than three months, have your chair inspected by an authorized supplier before use.

R. CHECK-OUT

After the wheelchair is assembled and adjusted, it should roll smoothly and easily. All accessories should also perform smoothly. If you have any problems, follow these procedures:

1. **Review the set-up and check-out sections and operating guide to make sure chair was properly prepared.**
2. **Review troubleshooting guide.**
3. **If your problem persists, contact your authorized supplier. If you still have a problem after contacting your authorized supplier, contact Sunrise customer service. See the introduction page for details on how to contact your authorized supplier or Sunrise customer service.**

⚠ WARNING

The owner of this chair is responsible for making sure that it has been setup and adjusted by a trained service professional under the advice of a healthcare advisor. Service and/or adjustments should only be done with the advice of a healthcare professional. Always use parts and/or accessories that have been recommended and approved by Sunrise Medical when servicing this chair.

A. DEALER SERVICE INTRODUCTION

1. At least once per year, this chair should have a complete inspection, safety check, and regular service made by an authorized dealer.
2. Torque settings— A torque setting is the optimum tightening which should be made on a particular fastener. It is important to use proper torque settings where specified. When not specified, torque settings should be 60 in-lbs
3. If you have discovered a worn, bent, or damaged part, repair or replace them with recommended parts **before returning this chair to service.**
4. All major maintenance and repair work should be done by the authorized dealer.

B. CRITICAL MAINTENANCE TIPS

1. Torque settings:

A torque setting is the optimum tightening which should be made on a particular fastener. It is important to use proper torque settings where specified. When not specified, torque settings should be 60 in-lbs

2. Dealer Service and Adjustment Reference materials:

Go to www.sunrisemedical.com for parts manuals, instruction sheets, and instructional videos that will aid in the repair of the Quickie 2 Family of wheelchairs.

C. CLEANING

1. Paint Finish

- a. Clean the painted surfaces with mild soap or detergent.
- b. Protect the paint with a coat of non-abrasive auto wax.

2. Axles and Moving Parts

- a. Clean around axles and moving parts with a slightly damp (not wet) cloth.
- b. Wipe off or blow away any fluff, dust or dirt on axles or moving parts.
- c. **DO NOT USE 3 in 1 oil, or WD-40® for lubrication. Only use Teflon based Lubricant when working on this wheelchair.**

D. FIXED REAR AXLE - HEIGHT ADJUSTABLE (QX) 1 2

CAUTION - Adjusting the chair's floor to seat height will require re-adjusting the location of the wheel locks, caster wheels, and rear anti-tips, please see corresponding sections in this owner's manual for correct adjustment.

1. Rear seat to floor height

- a. Remove rear wheels
- b. Using 2 x 1-1/8" wrenches, remove the axle sleeve assembly(A) from the axle plate(D) making note of the wheel spacing (distance between wheel and axle plate)
- c. After measuring the best height for the user, move the axle assembly up or down to desired position using one of the height adjustment holes(B) spaced 1" apart.
- d. Insert the axle sleeve assembly back into axle plate, and evaluate correct wheel spacing. Torque the axle nuts to 30ft-lbs.
- e. Repeat on opposite side of wheelchair, making sure to achieve the same axle height.

2. Adjusting Wheel Camber

Camber can be slightly adjusted by adding or removing camber spacers(E) between the axle plate(D) and rear frame tube(G). To make this adjustment:

- a. Remove the rear wheel.
- b. Using a 10mm wrench and socket remove axle plate bolts(C) and axle plate(D).
- c. Add or remove camber spacers(E) between rear frame and axle plate. Unused camber spacer(F) can be added on the inside of the frame tube.
- d. Using a torque wrench reinstall axle plate bolts. Torque the hardware to 65 in-lbs.
- e. Reinstall rear wheel.
- f. Repeat on opposite side of wheelchair.
- g. If desired, add or remove spacers between axle plate and frame. Use one spacer for a 2° camber, two spacers for a 4° camber, or zero spacers for 0° camber.



TOOLS YOU WILL NEED

1. Imperial Hex key set
2. Metric Hex key set
3. Imperial Open-end Wrench set
4. Metric Open-end Wrench set
5. Torque wrench
6. Imperial Hex bit Socket set
7. Metric Hex bit Socket set
8. Phillips and Flat screwdrivers

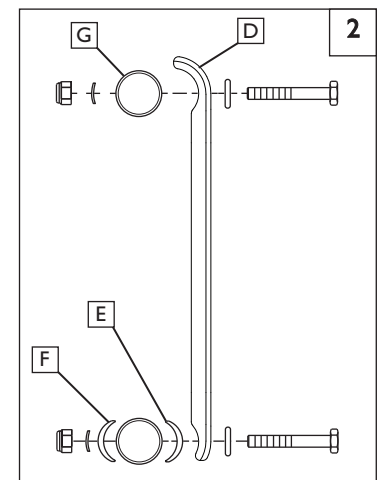
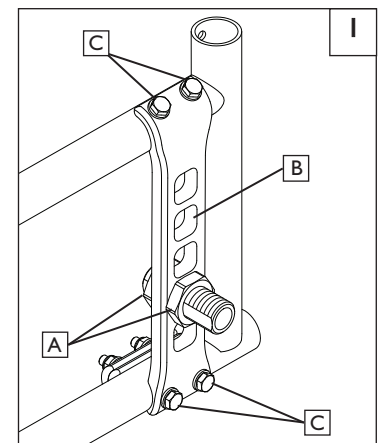

E. 3 AXIS ADJUSTABLE REAR AXLE SYSTEM (QXI) 3 4 5

The most important adjustment on your Quickie wheelchair is the position of the rear axle. The center of gravity, wheel camber and wheelbase are all determined by the axle adjustment.

Use a torque setting of 144 in.-lbs. when adjusting rear axle.

WARNING

The more you move your rear wheels forward, the more likely your chair will tip over backwards. Always make adjustments in small increments, and check the stability of your chair with a spotter to prevent a tip-over. We recommend that you use anti-tip tubes until you adapt to the change and are sure you are not at risk to tip over. Refer to additional Warnings in Section VI "Falls and Tip-Overs".

NOTE—Adjusting your chair's center of gravity will require re-adjusting the location of the wheel locks (if provided). See "Wheel Locks" section, for instructions on adjusting the wheel locks.

1. Center of Gravity 3

- Remove rear wheels
- Using a 10mm wrench loosen both bolts (A) to the point where the axle plate system (B) can move fore and aft.
- Determine the new Center Of Gravity by sliding the axle plate (B) fore or aft. Once a new location is found ensure the bottom section of the axle plate (B) is indexed into track (C) provide on the frame and the top of the axle system is perpendicular to the lower frame.
- Using a 10mm wrench tighten both bolts using a torque setting of 144 in.-lbs.
- Repeat process on opposite side of the wheelchair. Using the frame track system on the inside of the bottom frame (C) or a tape measure indexed from the rear vertical part of the frame ensure both sides of the wheelchair are set in the same Center Of Gravity setting prior to use.
- Reinstall rear wheels.

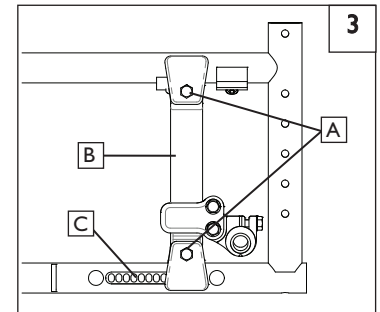

2. Adjusting Wheel Camber (Dual adjustment Camber Sleeve) 4

- Remove the rear wheels
- Using a 10mm wrench loosen both bolts (D) to the point where the camber sleeve (E) can be rotated.
- For 0° of camber, rotate the Camber Sleeve so that the notch in the sleeve faces in the "up" position.
- For 3° of camber, rotate the Camber sleeve(E) 180 degrees so that the notch in the sleeve faces in the "down" position.

NOTE - If you have a fixed Camber sleeve you must replace the Camber sleeves on both the left and right sides of your chair to gain a different camber.

- Using a 10mm wrench, tighten the bolts back in place. Use a torque setting of 60 in.-lbs.
- Repeat process on opposite side of the wheelchair.

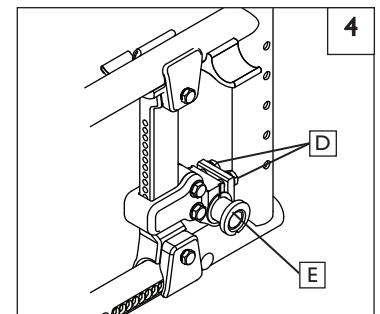

3. Wheel Base Width Adjustment 5

Adjusting the wheelbase width allows the rider the option to move the wheels closer or further away from the hips. It also compensates for camber adjustment and gives the proper wheel spacing to maximize pushing efficiency.

- Remove rear wheels.
- Using a 10mm wrench loosen both bolts (F) to the point where the camber sleeve (G) can be moved.
- Slide camber sleeve (G) in or out to new location.
- Using a 10mm wrench, tighten the bolts to a torque setting of 60 in.-lbs.
- Repeat this on opposite side of the wheelchair.

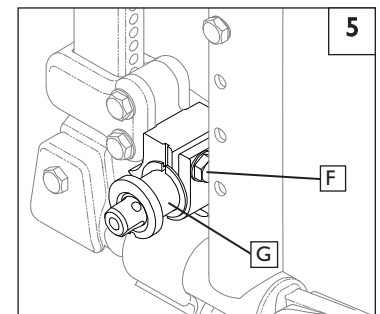

4. Seat Height Adjustment 6

- Remove rear wheels
- Using a 10mm wrench remove the top fastener (H) and loosen the bottom fastener (I).
- With a ratchet motion move the axle bracket (J) up or down to the new location.
- Using a 10mm wrench, tighten the bolts. Use a torque setting of 144 in.-lbs.
- Repeat process on opposite side of the wheelchair. Ensure new desired height is the same for both the left and right side of the frame. Use the index holes on the axle plate as a reference.

NOTE - A front caster adjustment should be made to correspond with any change in seat height.

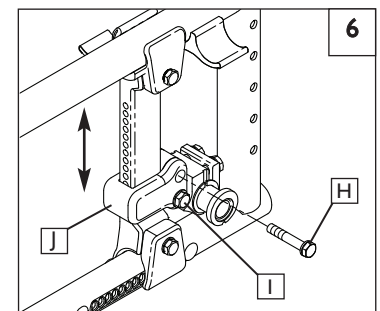

F. REAR WHEEL AXLE NUT ADJUSTMENT 7 8

The rear wheel axle (B) attaches the rear wheel (E) to the axle sleeve (F). When the detent balls (D) engage into the camber plug the rear wheel effectively becomes locked onto the chair. Pushing the quick-release button (A) disengages the detent balls and allows removal of the axle and wheel assembly.

To adjust the axle you will need a 3/4" wrench to turn the adjustment nut (C). You will also need a 1/2" wrench to securely hold the detent ball end of the axle to prevent it from turning.

If the wheel and axle will not lock into the axle sleeve then the axle requires adjustment. Turn the nut counter-clockwise approximately 1/4 revolution and try to lock the axle into the camber plug. If it doesn't lock, continue making small nut adjustments until it securely locks.

If the wheel is locked on the chair but there is excessive wheel play (the wheel hub can be pushed back and forth on the axle) then adjust the nut clockwise until there is no perceptible gap between the wheel and camber tube and the axle is securely locked onto the chair.

CAUTION– Quick-release button (A) must be flush with the edge of the wheel hub for detent balls (D) to be engaged and locked.

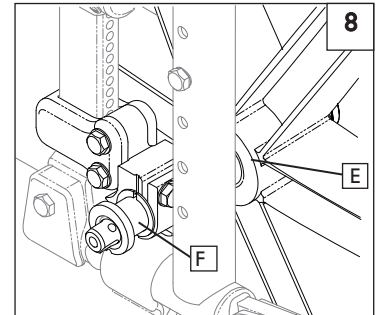
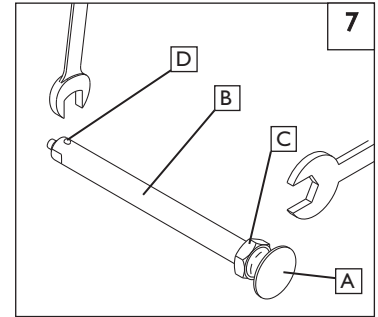

G. WHEEL LOCKS 9 10

The Quickie QXi wheelchair is shipped with one of four types of wheel locks. Wheel locks are installed at the factory unless you have requested otherwise.

Use a torque setting of 144 in.-lbs. when setting up wheel locks.

1. High-Mount Push-to-Lock or Pull-to-Lock , Wheel Locks Adjustment

- Using a 3/16 inch hex key, turn one of the screws (G) in the clamp counterclockwise one-quarter turn.
- Repeat the same process with the second of the two screws.
- Alternately loosen the screws (two turns each) until both screws are removed.
- Slide clamp toward the rear wheel until the wheel lock is embedded into the tire to prevent wheel movement, when in the locked position.
- Tighten screws to 144 in.-lbs.

2. Ergo Scissor Wheel Locks or Compact Wheel Locks

Loosen the screws (G) on the top of each clamp using a 3/16 inch hex key. Slide assembly toward rear wheel until clamp embeds into tire to prevent wheel movement when in locked position. Adjust angle position. Tighten screws to 144in.-lbs.

NOTE– Clamp and wheel lock may need to be rotated to clear frame tubing.

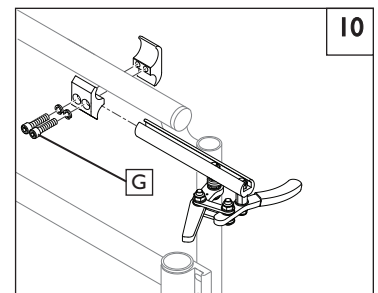
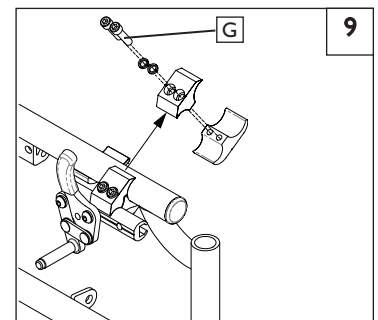

H. CASTER FORKS 11

Multi-hole caster forks allow the interchanging of some casters and adjusting seat height. To adjust, loosen the bolt (H) and remove the caster. Either change caster size and/or position the caster upward or downward in predrilled holes (1 inch apart) on caster fork. Replace bolt and tighten securely.

Use a torque setting of 75 in.-lbs. when adjusting the caster forks.

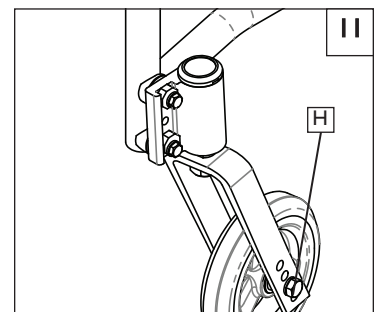

I. CASTERS

Use a torque setting of 144 in-lbs. when adjusting the casters.

1. Caster Angle Adjustment 12

For optimum performance, the caster housing should always be at a 90° angle to the floor (perpendicular to the ground). This adjustment is made with an eccentric (offset) attachment bolt(A).

- a. To change the angle, place the chair on a flat surface (such as a table).
- b. Remove the bolt nuts from the back side of the caster plate. The caster plate is slotted at the top and bottom for adjustment.
- c. Place a large right triangle against the table surface and the front surface of the caster bearing housing.
- d. This will align the caster stem rotational axis perpendicular to the floor surface.
- e. Rotate the eccentric bolts(A) independently until they fall into position.
- f. When the alignment is correct, retighten the two retaining bolts.
- g. Repeat the process for the other caster.

2. Caster Reversibility 13 14

The caster housing is generally mounted in a forward-facing position. If additional footrest clearance is necessary, the caster housing can be reversed. This will position the caster housing rearward to allow more clearance.

- a. To reverse the caster housing, the left housing should be mounted on the right side of the frame.
- b. The right housing should be mounted on the left side of the frame.

NOTE— Changing the caster to the trailing position will change the stability of the wheelchair. Prior to use ensure rider can safely operate the wheelchair.

J. ARMREST RECEIVER ATTACHMENT 15 16 17

1. Mounting

- a. Place armrest receiver hardware with clamp (C) onto the side frame.
- b. Using a 10mm wrench install fasteners (E) . Torque to 144 in-lbs.
- c. Install armrest(A) into receiver (B) to ensure proper alignment. Loosen and retighten fasteners (D) as needed.
- d. Repeat process on opposite side.

2. Adjustment

- a. To adjust the fit of the Single Post Armrest in the receiver, loosen the 4 hex bolts (D) by using a 10mm wrench.
- b. With the armrest assembly in the receiver (B), press firmly on the outside of the receiver.
- c. Maintain pressure on the receiver and re-tighten two of the hex bolts (D).
- d. Remove the armrest assembly and re-tighten the remaining two hex bolts(D).
- e. The armrest will fit firmly in the receiver and lessen any noise that may result from vibration.

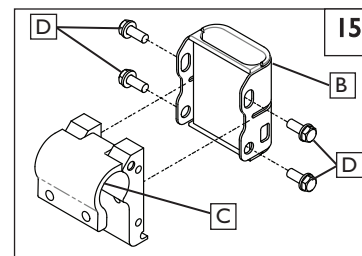
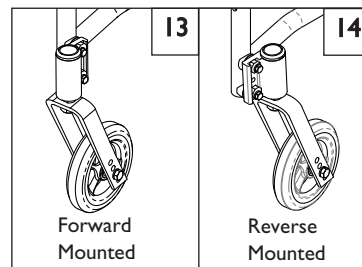
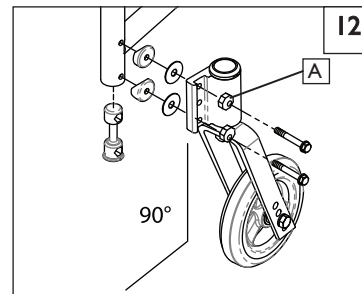

B. Receiver
C. Clamp
D. Receiver adjustment hardware

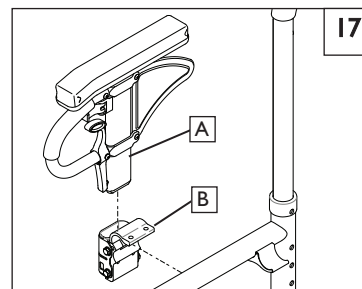
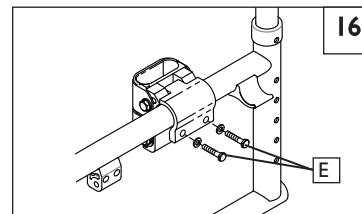

K. PADDED SWING-AWAY ARMRESTS 19**I. Mounting and Height adjustment**

- a. Swing-away armrests(B) can be detached or can swing away to allow lateral transfers. They are height adjustable (1" increments) by moving bolt (A) up or down in predrilled holes on armrest bracket.
- b. Additional height can be achieved by removing bolts (C) and moving the receiver(D) or the entire hardware assembly up or down the rear frame tube. Ensure bolts (C) are retightened (torque to 144 in lbs).

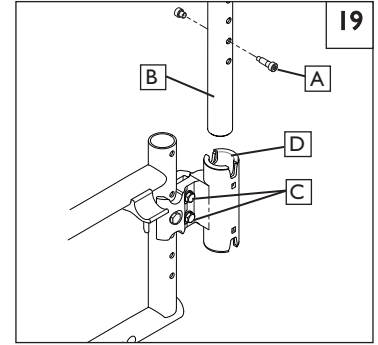
**L. SWING-IN/SWING-OUT HANGERS AND FOOTRESTS** 20**I. Height Adjustment**

NOTE—It is recommended that you maintain a minimum of 2.0 inches between the lowest point on the footrest and the floor.

- a. Loosen set screw (E) using a 3/16 inch hex key.
- b. Slide footrest extension up or down inside frame tube to desired height.
- c. Tighten set screw. Use a torque setting of 144 in-lbs (16.27 Nm).

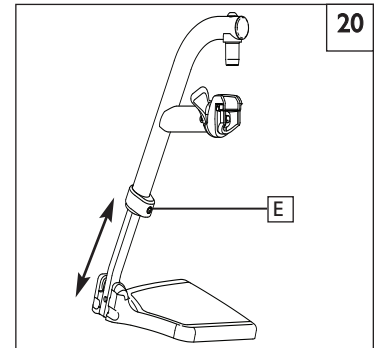
**M. ELEVATING / ARTICULATING LEGREST (Optional)** 21**I. Height Adjustment (see “Swing-in/Swing -out Hangers” above)****2. ELR Pad height Adjustment**

- a. To raise or lower the legrest Pad, Loosen the Nylock Nut(G) with a 3/16” wrench and lift or lower to desired position.
- b. Once your preferred position is reached, tighten the Nut to 60 in-lbs.

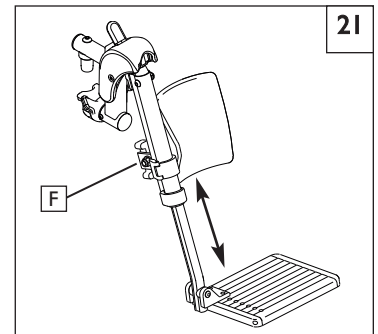
**N. ANGLE ADJUSTABLE FOOTPLATES** 22

Adjusting the angle on the Footplate

- a. Loosen the flat head screws (G).
- b. Adjust footplate (H) to desired angular position.
- c. Re-tighten hardware (G).

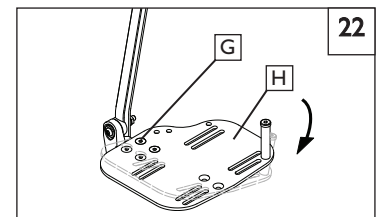

O. BACKREST 23**1. Height Adjustment**

- Using a 10mm wrench remove fastener(A).
- Adjust to the desired backrest height. Back height is measured with the chair in the unfolded position, from the top of the seat sling to the highest point of the back upholstery in a vertical straight line.
- Align the threaded insert in the upper backrest cane to the nearest hole in the frame.
- Insert fastener (A) through the frame and thread into the insert in the back cane.

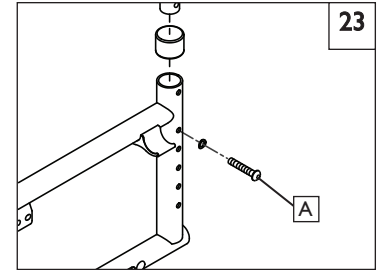

NOTE– Do not use the top angle adjustment hole for adjusting the back height.

NOTE– Use a torque setting of 144 in-lbs. when adjusting the backrest.

P. ANGLE ADJUSTABLE BACKREST (Optional) 24 25**1. Angle Adjustment**

- Loosen button head screws (B) until the eccentric offset washer (C) moves freely.
- Adjust backrest to desired angle, aligning eccentric offset washer in the slot.
- Tighten button head screws.
- Repeat for the opposite side.

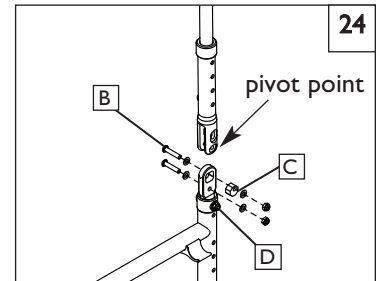
**2. Pivot Point Height Adjustment**

- Remove button head screw (D) from the frame.
- Adjust backrest to obtain desired pivot point height.
- Replace and Tighten button head screws.
- Repeat for the opposite side.

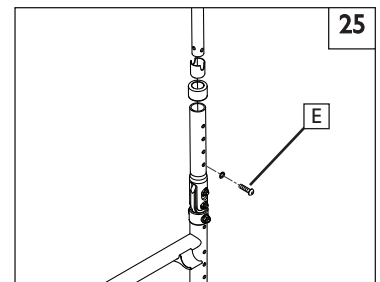
**3. Backrest Height Adjustment**

- Remove button head screw (E).
- Adjust back tube to the desired height.
- Replace and tighten button head screw.
- Repeat for the opposite side.

NOTE– Use a torque setting of 144 in-lbs. when adjusting the backrest

Q. SEATING AND SEAT SLING UPHOLSTERY 26

The seat sling can be adjusted through the use of hook and loop material beneath the seat. Seat sling also includes a folding strap on the seat to assist in folding the chair.

NOTE–The seat sling folding strap is not intended as a carrying strap.

1. Adjustment

- Using a flathead screwdriver, remove seat rail end caps at the front of the chair (F).
- Slide the seat sling, plastic retaining rods, and spacers (if present) from the channels in the seat rails.
- Readjust hook and loop material to obtain the desired tension in the seat sling.
- Reinsert the seat sling and plastic retaining rods into the channels in the seat rails.
- Replace the end caps.

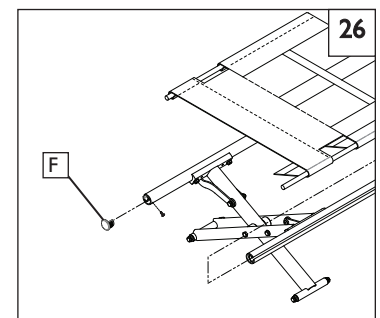
**R. REMOVING THE SEAT RAIL** 27

Detach the seat rails by removing the two bolts (G) attaching the seat rail (H) to the cross brace.

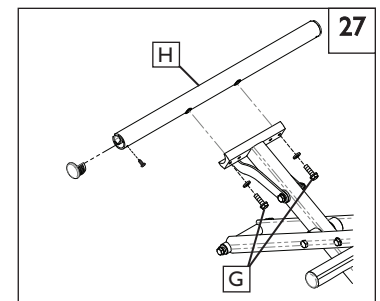

S. BACKREST TENSION ADJUSTABLE 28 29 30

I. To install the Backrest Tension Adjustable

- a. Slide Velcro straps (D) over the backrest frame (E) section. Make sure to include at least one strap below the towel bar (if using a rigid chair).
- b. Tighten the straps appropriately to desired tension level. **DO NOT** overtighten straps as this will cause undue strain upon the chair backrest frame (E).
- c. If using integral push handles (F), slide straps from bottom of backrest upward.
- d. Install backrest cover at desired level and fold over rear of Velcro strapping system (G). The Quickie patch should be upright on the rear of the chair.
- e. Finish installation by placing vanity flap (center panel) down onto Velcro on the seat sling to secure attachment (H).

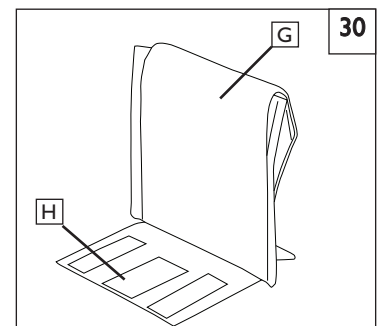
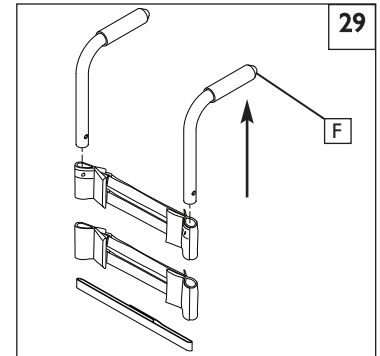
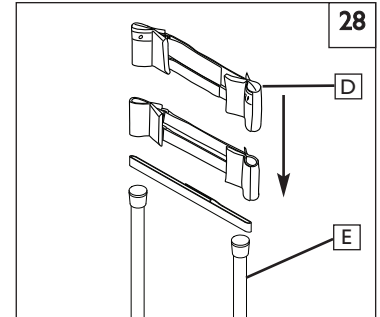

2. Adjusting the Backrest Tension Adjustable

Suggest using anti tips while making any adjustments. Ensure anti tips are safely secured and in a position to prevent the wheelchair from tipping backwards.

- a. User can transfer into wheelchair. Place wheel locks in the locked position
- b. From the rear of the wheelchair the attendant can lift the Vanity Flap (Center panel) to access the strap system. Adjust straps for optimal balance and truck alignment. Ensure the Velcro straps has a minimum of 2" of engagement, hook securing to loop. Press the Velcro together to ensure it's securely engaged.
- c. Once adjustments have been finalized replaced Vanity Flap to its original position.

WARNING

Any changes made to the straps will affect the center of gravity. Suggest the user has the attendant stationed behind the wheelchair to prevent the wheelchair from tipping backwards while they become accustomed to the adjustment.

T. SIDEGUARD HARDWARE (Optional) 31

I. Installation of side guard hardware

- a. Position outer receiver hardware (A) on frame.
- b. On corresponding inside of the frame position inner clamping hardware (B)
- c. Insert two bolts (C) with washer (E) and tighten using 3/16 inch hex key
- d. Your sideguard (D) can now be inserted into the receiver.

NOTE—After installing receiver hardware and inserting side guard check for interference. Don't operate the wheelchair that as interference with these other components.

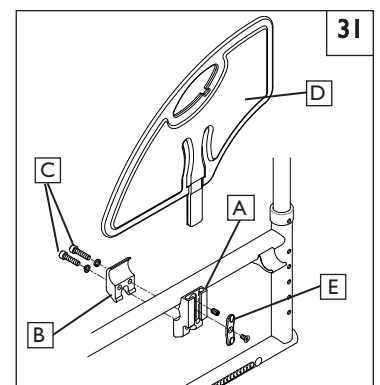

U. CHECK-OUT

After the wheelchair is assembled and adjusted, it should roll smoothly and easily. All accessories should also perform smoothly. If you have any problems, follow these procedures:

1. Review the set-up and check-out sections and operating guide to make sure chair was properly prepared.
2. Review troubleshooting guide.
3. If your problem persists, contact your authorized supplier. If you still have a problem after contacting your authorized supplier, contact Sunrise customer service. See the introduction page for details on how to contact your authorized supplier or Sunrise customer service.

A. FOR LIFETIME

Frame and cross-brace (if applicable) warranty:

1. Although the anticipated useful service time of this wheelchair is five years, Sunrise guarantees the frame and cross brace against defects in material and workmanship for life or for as long as the original purchaser owns the chair.
2. This warranty does not apply if:
 - a. The chair is subject to abuse
 - b. The chair is not maintained as recommended in the owner's manual
 - c. The chair is transferred to a different person from the original owner

B. FOR ONE (1) YEAR

We warrant all Sunrise-made parts and components of this wheelchair against defects in materials and workmanship for one year from the date of first consumer purchase.

Backrest Tension Adjustable (Balistic & 3DX Vented)

Each Backrest Tension Adjustable is carefully inspected and tested to provide peak performance. Every Backrest Tension Adjustable is guaranteed to be free from defects in materials and workmanship for a period of twelve (12) months from the date of purchase provided normal use. Should a defect in materials or workmanship occur within twelve months from the original date of purchase, Sunrise Medical will, at its option, repair or replace it without charge. This warranty does not apply to puncture, tears or burns. Claims and repairs should be processed through the nearest authorized supplier. Except for express warranties made herein, all other warranties including implied warranties of merchantability and warranties of fitness for particular purpose are excluded. There are not warranties which extend beyond the description of the face hereof. Remedies for breach of express warranties herein are limited to repair or replacement of the goods. In no event shall damages for breach of any warranty include any consequential damages or exceed the cost of non-conforming goods sold.

C. LIMITATIONS

1. We do not warrant:
 - a. Tires and tubes, upholstery, pads and push-handle grips.
 - b. Damage from neglect, accident, misuse, or from improper installation or repair.
 - c. Products modified without Sunrise Medical's express written consent.
 - d. Damage from exceeding the weight limit.
2. This warranty is VOID if the original chair serial number tag is removed or altered.
3. This warranty applies in the USA and Canada only. Check with your supplier to find out if international warranties apply.
4. This warranty is not transferable and only applies to the first consumer purchase of this wheelchair through an authorized Sunrise Medical dealer.

D. WHAT WE WILL DO

Our sole liability is to repair or replace covered parts. This is the exclusive remedy for consequential damages.

E. WHAT YOU MUST DO

1. Obtain from an authorized supplier, while this warranty is in effect, prior approval for return or repair of covered parts.
2. Return the wheelchair or part(s), freight pre-paid, to Sunrise Medical at: 2842 Business Park Avenue, Fresno, CA 93727-1328.
3. Pay the cost of labor to repair, remove or install parts.

F. NOTICE TO CONSUMER

1. If allowed by law, this warranty is in place of any other warranty (written or oral, express or implied, including a warranty of merchantability, or fitness for a particular purpose).
2. This warranty gives you certain legal rights. You may also have other rights that vary from state to state.

G. ADDITIONAL WARRANTY INFORMATION

For goods provided by Sunrise Medical Pty Ltd in Australia, our goods come with a guarantee by Sunrise that cannot be excluded under the Australian Consumer Law. You are entitled to a replacement or refund for a major failure and for compensation for any other reasonably foreseeable loss or damage. You are also entitled to have the goods repaired or replaced if the goods fail to be of acceptable quality and the failure does not amount to a major failure. The benefits to you given by this warranty are in addition to your other rights and remedies under a law in relation to the goods to which the warranty relates.

Record your serial number here for future reference:
